

WAR DEPARTMENT TECHNICAL MANUAL

SIGNAL GENERATORS
TS-155/UP AND TS-155A/UP

Change in force C1 and C2

TECHNICAL MANUAL

SIGNAL GENERATORS TS-155/UP AND TS-155A/UP

TM 11-2657

CHANGE No. 2



HEADQUARTERS,
DEPARTMENT OF THE ARMY,
WASHINGTON, D.C., 25 September 1963

TM 11-2657, 8 February 1945, is changed as follows:

Page 1. After paragraph 1, add:

1.1. Index of Publications

Refer to the latest issue of DA Pam 8104 to determine whether there are new editions, changes, or additional publications pertaining to the equipment. DA Pam 810-4 is an index of current technical manual, technical bulletins, supply bulletins, lubrication orders, and modification work orders available through lubrication supply channels. The index lists the individual parts (-10, -20, -35P, etc.) and the latest changes to and revisions of each equipment publication.

1.2. Forms and Records

a. *Reports of Maintenance and Unsatisfactory Equipment.* Use equipment forms and records in accordance with instructions in TM 8-750.

b. *Report of Damaged or shipment.* Fill out and

forward DD Form 6 (Report of damaged or improper Shipment) as prescribed in AR 700-58 (Army), NAV-SANDA Publication 378 (Navy), and AFR 71-4 (Air Force).

c. *Reporting of Equipment Manual Improvement.* The direct reporting by the individual user of errors, omissions, and recommendations for improving this manual is authorized and encouraged. DA Form 2028 (Recommended changes to DA technical manual parts lists or supply manual 7, 8, or 9) will be used for reporting these improvements. This form will be completed in triplicate using pencil, pen, or typewriter. The original and one copy will be forwarded direct to Commanding Officer, U. S. Army Electronics Materiel Support Agency. ATTN: SELMS-MP, Fort Monmouth, N. J. 07708. One information copy will be furnished to the individual immediate supervisor (officer, noncommis-sioned officer, supervisor, etc.).

Page 18. Delete sections V, VI, and VII except figures 10 and 11 and substitute:

Section V. ORGANIZATIONAL MAINTENANCE

16. Scope of Maintenance

The maintenance duties assigned to the operator and organizational repairman of Signal Generators TS-155/UP and TS-155A/UP are listed below together with a reference to the paragraphs covering the specific maintenance functions.

a. Daily preventive maintenance checks and services (par. 19).

b. Weekly preventive maintenance checks and service (par. 20).

c. Monthly preventive maintenance checks and services (par. 21).

TAGO 6180A-704461—October 1963

- d. Quarterly preventive maintenance checks and services (par. 22).
- e. Cleaning (par. 23).
- f. Touchup painting (par. 24).
- g. Lubrication (par. 25).
- h. Moistureproofing and fungiproofing (pars. 28-30).

17. Preventive Maintenance.

Preventive maintenance is the systematic care, servicing, and inspection of equipment to prevent the occurrence of trouble, to reduce downtime, and to assure that the equipment is serviceable.

a. *Systematic Care.* The procedures given in paragraphs 19 through 28 cover routine systematic care and cleaning essential to proper upkeep and operation of the equipment.

b. *Preventive Maintenance Checks and Services.* The preventive maintenance checks and services charts (pars. 19-22) outline functions to be performed at specific intervals. These checks and services are to maintain army electronic equipment in a combat-serviceable condition; that is, in good general (physical) condition and in good operating condition. To

assist operators in maintaining combat serviceability, the charts indicate what to check, how to check, and what the normal conditions are; the Reference column lists the illustrations, paragraphs, or manuals that contain detailed repair or replacement procedures. If the defect can not be remedied by performing the corrective actions listed, higher echelon maintenance or repair is required. Records and reports of these checks and services must be made in accordance with the requirements set forth in TM 38-760.

18. Preventive Maintenance Checks and Services Periods

Preventive maintenance checks and services of Signal Generators TS-155/UP and TS-156A/UP are required daily, weekly, monthly, and quarterly.

a. Paragraph 19 specifies the checks and services that must be accomplished daily (or at least once each week if the equipment is maintained in standby condition).

b. Paragraphs 20, 21, and 22 specify additional checks and services that must be performed on a weekly, monthly, and quarterly basis, respectively.

19. Daily Preventive Maintenance Check and Services Char

Sequence No.	Item	Procedure	References
1	Completeness	See that the equipment is complete SIG 7 & 8 TS-155/UP.	
2	Exterior surfaces	Clean the exterior surfaces, including the panel and meter glasses (par. 23). Check all meter glasses and Indicator lenses for cracks.	
3	Connections	Check the tightness of all connectors.	
4	Controls and indicators	While making the operating checks (item 6), observe that the mechanical action of each knob, dial, and switch is smooth and free of external or internal binding, and that there is no excessive looseness. Also, check the meter for sticking or bent pointer.	
5	Operation	During normal operation, be alert for unusual performance or condition.	

20. Weekly Preventive Maintenance Checks and Service Chart

Sequence No.	Item	Procedure	References
1	Cables.....	Inspect cords, cables, and wires for chafed, cracked, or frayed insulation. Replace connectors that are broken, arced, stripped, or worn excessively.	
2	Handles and latches.....	Inspect handles, latches, and hinges for looseness. Replace or tighten as necessary.	
3	Metal surfaces.....	Inspect exposed metal surfaces for rust and corrosion. Touchup paint as required (par. 24).	

21. Monthly Preventive Maintenance Check and Services Chart

Sequence No.	Item	Procedure	References
1	Lubrication	Lubricate the equipment (par. 25).	
2	Pluckout items.....	Inspect seating of pluckout items. Make certain that tube clamps grip tube bases tightly.	
3	Transformer terminals...	Inspect the terminals on the power transformer. There should be no evidence of dirt or corrosion.	
4	Terminal blocks.....	Inspect terminal blocks for loose connections and cracked or broken insulation.	
5	Resistors and capacitors	Inspect the resistors and capacitors for cracks, blistering, or other detrimental defects.	
6	Gaskets and insulators..	Inspect gaskets, insulators, bushings, and sleeves for cracks, chipping, and excessive wear.	
7	Interior	Clean interior of chassis and cabinet	

22. Quarterly Preventive Maintenance Checks and Services Chart

Sequence No.	Item	Procedure	References
1	Publications.....	See that all publications are complete, serviceable and current	DA Pam 310-4.
2	Modifications.....	Check DA Pam 310-4 to determine if new applicable MWO's have been published. All urgent MWO's must be applied immediately. All normal MWO's must be scheduled.	TM 38-750 and DA Pam 3104.
3	Spare parts	Check all spare parts (operator and organizational) for general condition and method of storage. There should be no evidence of overstock, and all shortages must be on valid requisitions.	SIG 7& 8, TS-155/UP.

23. Cleaning

Inspect the exterior of the (equipment. The exterior surfaces should be clean, and free of dust, dirt, grease, and fungus.

a. Remove dust and loose dirt with a clean soft cloth.

Warning: Cleaning compound is flammable and its fumes are toxic. Provide adequate ventilation. Do not use near a flame.

b. Remove grease, fungus, and ground-in dirt from the cases; use a cloth dampened (not wet) with

cleaning compound (Federal Stock No. 7930-395-9542). After cleaning, wipe dry with a cloth.

c. Remove dust or dirt from connectors with a brush.

Caution: Do not press on the meter face (glass) when cleaning; the meter may become damaged.

d. Clean the front panel, meter, and control knobs; use a soft clean cloth. If necessary, dampen the cloth with water; mild soap may be used for more effective cleaning. Wipe dry with a cloth.

TAGO 6180A

24. Touchup Painting Instructions

Remove rust and corrosion from metal surfaces by lightly sanding them with fine sandpaper. Brush two thin coats of paint on the bare metal to protect it from further corrosion. Refer to the applicable cleaning and refinishing practices specified in TM 9-213.

25. Lubrication

Apply a few drops of Oil, Engine, U.S. Army Spec No. 2-104B, to the RF attenuator and RF tuning gear after they have been thoroughly clean

Page 28, part five. Delete the note beneath heading.

Page 54. After paragraph 44, add:

**APPENDIX
REFERENCES**

DA Pam 310-4	Index of Technical Manual, Technical Bulletins, Supply Bulletins, Lubrication Order:, and Modification Work Orders
SIG 7&8, TS-155/UP	Organizational Maintenance Allowances and Field and Depot Maintenance Stockage Guide for Signal Generators TS-155A, B, C, E/UP.
TM 9-213	Painting Instructions for Field Use
TM 38-750	The Army Equipment Record System and Procedures

Page 55. Delete the APPENDIX

TAGO 6180A

BY ORDER OF THE ARMY

EARLE G. WHEELER,
General, United States Army,
Chief of Staff.

Official:

J. C. LAMBERT,
Major General, United State, Army,
The Adjutant General.

Distribution:

Active Army

DASA (6)
USASA (2)
CNGB (1)
CofEngrs (1)
TSG (1)
CSigO (7)
CofT (1)
OCofSptS (1)
USA CD Agcy (1)
USCONARC (5)
USAMC (5)
ARADCOM (2)
ARADCOM Rgn (2)
OS Maj Comd (3)
OS Base Comd (2)
LOGCOMD (2)
USAE COM (5)
USAMICOM (4)
USASCC (4)
MDW (1)
Armies (2)
Corps (2)
USA Corps (3)
USATC AD (2)
USATC Engr (2)
USATC Inf (2)
USATC. Armor (2)
USASTC (5)
Instl (2) except
Ft Monmouth (65)
Svc Colleges (2)
Br Svc Sch (2)
GENDEP (OS) (2)
Sig Sec, GENDEP (6)
Sig Dep (OS) (12)
Army Dep (2) except
 Ft Worth (8)
 Lexington (12)
 Sacramento (28)
 Tobyhanna (12)
USA Trans Tm1 Comd (1)

NG: State AG (3).

USAR: None

For explanation of abbreviations used, see AR 320-50

Army Tm1 (1)
POE (1)
USAOSA (1)
AMS (1)
WRAMC (1)
AFIP (1)
Army Pic Cen (2i)
USA Elct RD Actv, White Sands (13)
USA Elct RD Acty, Ft Huachuca (2)
USA Mbl Spt Cen (1)
USA Elct Mat Agcy (12)
Chicago Proc Dist (1)
USARCARIB Sig Agcy (1)
Sig Fld Maint Shops (3)
Units org under fol TOE:
 6-125 (2)
 6-126 (2)
 6-200 (2)
 6-225 (2)
 6-228 (2)
 6-525 (2)
 6-535 (2)
 6-537 (2)
 6-575 (2)
 6-577 (2)
 11-7 (2)
 11-16 (2)
 11-57 (2)
 11-98 (2)
 11-117 (2)
 11-155 (2)
 11-157 (2)
 11-500 (AA-AE) (4)
 11-557 (2)
 11-587 (2)
 11-592 (2)
 11-597 (2)
 29-56 (2)
 39-65 (2)
 57 (2)

TAGO 6180A

U. S. GOVERNMENT PRINTING OFFICE: 1963

GPO 898-236

This publication is a courtesy quick copy from the UNITED STATES ARMY PUBLICATIONS CENTER, ST. LOUIS, MISSOURI, to meet your needs while we are replenishing our regular stock.

**TECHNICAL MANUAL
SIGNAL GENERATORS TS-155/UP AND TS-155A/UP**

CHANGES
No. 1 }
}

WAR DEPARTMENT
Washington 25, D.C.,
10 August 1945

TM 11-2657, 8 February 1945, is changed as follows:

4. TECHNICAL CHARACTERISTICS OF SIGNAL GENERATOR TS-155/UP

* * * * *

Externally synchronized requirements
External trigger requirements
Trigger frequency -----120 to 2,000 cycles
* * * * *

Polarity-- Either positive or negative
Amplitude -----15 to 100 volts
Negative pulses work * * * than 470,000 ohms
Rise time---- Less than 0.2 microsecond rise time to 20 volts
* * * * *

LIST OF COMPONENTS

e. *Tube Complement*

Tube Number	Type	Function
V5 A and B	6SN7 GT	Blocking oscillator, cathode follower
V6	OD3/VR-150	Voltage * * * multivibrator
V7	OC3/VR-105	Voltage regulator for thermistor bridge
* * * * *	* * * * *	* * * * *

6. DIFFERENCES IN MODELS

Signal Generator TS-155/UP * * * used on the TS-155/UP. The R. F. TUNING dial is calibrated for increasing wavelength with increasing reading on the TS-155/UP and for increasing frequency with increasing reading on the TS-155A/UP. The other differences * * * are listed below.

* * * * *

Figure 7. Coarse PULSE DELAY settings with fine PULSE DELAY set at midpoint

13. STARTING PROCEDURE

f. Turn the METER.* * * meter reads zero

CAUTION: (Added) Always set meter to zero before turning R. F. OSC switch to ON

14. SYNCHRONIZATION

b. *Internal Synchronization*

* * * * *

(3) (Added.) Turn the INPUT TRIGGER switch to +

15. TESTING OVER-ALL PERFORMANCE OF RADAR SYSTEM

* * * * *

c. *Interpretation of Tests*

(3) *Explanation, of Table 11*

* * * * *

This publication is a courtesy quick copy from the UNITED STATES ARMY PUBLICATIONS

CENTER, ST. LOUIS, MISSOURI, to meet your needs while we are replenishing our regular stock.

TM 11-2657
C1

**TECHNICAL MANUAL
SIGNAL GENERATORS TS-155/UP AND TS-155A/UP**

CHANGES
No. 1

WAR DEPARTMENT
Washington 25, D. C.
10 August 1945

TM 11-2657, 8 February 1945, is changed as follows:

4. TECHNICAL CHARACTERISTICS OF SIGNAL GENERATOR TS-155/UP

* * * * *

Externally synchronized.

External trigger requirements.

Trigger frequency-. 120 to 2,000 cycles.

* * * * *

Polarity----Either positive or negative.

Amplitude-----15 to 100 volts.

Negative pulses work-----* * * than 470,000 ohms.

Rise time-----Less than 0.2 microsecond rise time to 20 volts.

* * * * *

5. LIST OF COMPONENTS.

* * * * *

e. *Tube Complement..*

Tube Number	Type	Function
V5 A and B	6SN7 GT	Blocking oscillator, cathode follower.
V6	OD3/VR-150	Voltage * * * multivibrator.
V7	OC3/VR-105	Voltage regulator for thermistor bridge.
**	*	* * *

* * * * *

6. DIFFERENCES IN MODELS.

Signal Generator TS-155/UP * * * used on the TS-155/UP. The R. F. TUNING dial is calibrated for increasing wavelength with increasing reading on the TS-155/UP and for increasing frequency with increasing reading on the TS-155A/UP. The other differences * * * are listed below.

* * * * *

Figure 7. Coarse PULSE DELAY settings with fine PULSE DELAY set at midpoint

13. STARTING PROCEDURE.

* * * * *

f. Turn the METER * * * meter reads zero.

CAUTION: (Added.) Always set meter to zero before turning R. F. OSC switch to ON.

* * * * *

14. SYNCHRONIZATION.

* * * * *

b. *Internal Synchronization.*

* * * * *

(3) (Added.) Turn the INPUT TRIGGER switch to +

15. TESTING OVER-ALL PERFORMANCE OF RADAR SYSTEM.

* * * * *

c. *Interpretation of Tests.*

* * * * *

(3) Explanation of Table II.

* * * * *

TABLE II
RADAR RANGE VS.
RADAR PERFORMANCE

Performance down in db	Percent of total effective range
0	100%
-1.5	92%
-3	84%

(4) Explanation of Table III. This table shows * * * of 1 milliwatt. This may also be expressed as -20 dbm, and this, as the table indicates, corresponds to an output power of 10×10^{-6} watts, or 10 microwatts, or 0.01 milliwatt.

VOLTAGE CHART

Tube	PIN								Selector switch
	1	2	3	4	5	6	7	8	
*		*		*		*		*	
V ₂	0 -36 0	140	11.7 11.7 3.3 to 13	2.3 to -6.8c 0.9 to 5.3 -70.7 to 7.5 ^b	145	11.7 11.7 3.3 to 13	0	6 ac	EXT CALIB INT
*		*		*		*		*	

3. MECHANICAL REPAIRS.

d. ATTENUATOR.

* * * * *

(2) The piston may * * * is fully compressed.

CAUTION: Unless a means * * not be removed. The adjusting screw on the attenuator is set at the factory so that when 200 milliwatts is fed into the R. F. jack and the attenuator piston is completely compressed, the monitoring meter gives a full-scale reading. The attenuator loop * * * may be destroyed.

44. ADJUSTMENTS.

* * * * *

In figure 23, on waveform No. 1, change "S₂ IN TRIG. IN. POSITION" to read: "S₂. IN INT TRIO POSITION."

In figure 24, indicate that the waveforms apply to the input and output sides of C6.

In figure 29, change the value of R46 (grid leak of V9) to read: "22,000."

42. TEST ANALYSIS DATA.

* * * * *

b. Voltage Chart. The following voltages * * * switch was off.

a. Adjustment of Electrical Constants of the Cavity for Optimum Operation with a Type 446B or 2C40 Tube.

* * * * *

(3) To check for * * * cylinder sleeve assembly.

* * * * *

(h) Turn the R. F. TUNING dial to read 45 (turn to read 55 for TS-155A/UP).

* * * * *

(j) Measure the frequency, or the wave-length, of the oscillator with the tuning dial set at 45 (55 for TS-155A/UP) (subpar. b, below). If the frequency, * * * directly to step n.

TABLE IV (Superseded)
CAVITY ADJUSTMENT
DATA FOR OPTIMUM
OPERATION

	Normal limits with tuning dial reading of 45 (55 for TS- 155A/UP)
Frequency in megacycles -----	2,812 to 2,785
Wavelength in centimeters-----	10.66 to 10.77
Length of grid cylinder-----	1 3/4" ± 3/16"

* * * * *
Figure 32. Calibration of Signal Generator TS-155/UP
with Wavemeter Test Set TS-117/GP.

e. Frequency Adjustment with Other Test Equipment. (Added.)

(1) If the test instrument being used to determine the r-f output does not contain a crystal rectifier, an adapter assembly or group of fittings is required for making the tests. The component parts of this assembly are listed in the following table.

Quantity	Name of unit	Dimensions (in.)			Weight (lb)	Stock No.
		Height	Width	Depth		
1	Radio Frequency Adapter UG-57/U -----	3/4	3/4	2	1/8	2Z7390-57
1	Crystal Adapter UG-119/P -----	3/4	3/4	2	1/8	2Z30119
1	Radio Frequency Adapter UG-28/U -----	5/8	1 3/4	2 3/4	3/16	2Z739-28
1	Tube (crystal) 1N21B (in Crystal Adapter UG-119/UP).	7/8				2J1N21B

The components of the adapter assembly can be requisitioned through channels if they are not supplied with the test equipment.

(2) The frequency of the signal generator may be adjusted using any calibrated resonant frequency device which is tunable in the frequency range of the signal generator. The adapter assembly is used with an echo box, a wavemeter, an oscilloscope, or other sensitive indicator. The wavemeter may be any absorption type covering the frequencies required. The oscilloscope should have an amplifier gain of 200 and a minimum bandwidth of 500,000 cycles. These values will give good results, although it may be possible to achieve some results with less gain and smaller bandwidth. It is possible to use a sensitive amplifier (giving a useful indication with a minimum input of 0.1 volt) as an indicator in place of the oscilloscope.

(3) Typical test instruments which may be used are: Echo Boxes TS-207/UP, TS-217/MPN-1, TS-238/GP, TS-270/UP, and TS-270A/UP; Frequency Meters I-140-A and I-183-A; Wavemeter TS-192/CPM-4; Test Set TS-3/AP; Wavemeter Test Set TS-117/GP; and Oscilloscopes BC-1060--A, BC-1060-B and I-134-B (DuMont model 224).

d. Installation of Adapter Assembly. (Added.)
Connect the adapter assembly as indicated in figures 33 and 34.

(1) Connect the free end of Cord CG-71/MPM (trigger cable) to the input signal terminals of the test oscilloscope (or other indicator).

(2) Connect the free end of Cord CG-70/MPM (antenna cable) to the frequency measuring device being used. For example: (a) If Test Set TS-3/AP is used, connect the r-f cord to the FREQ METER IN receptacle and connect the FREQ METER OUT cord to the CRYSTAL IN receptacle.

(b) If Wavemeter Test Set TS-117/GP is used, connect the r-f cord to the TUNE TO PEAK receptacle.

(c) If Frequency Meter I-183-A is used, connect the r-f cord to the TRACK connector and turn the SEARCH-TRACK switch to TRACK. If any other instrument is used, connect the r-f cord to the r-f input connector.

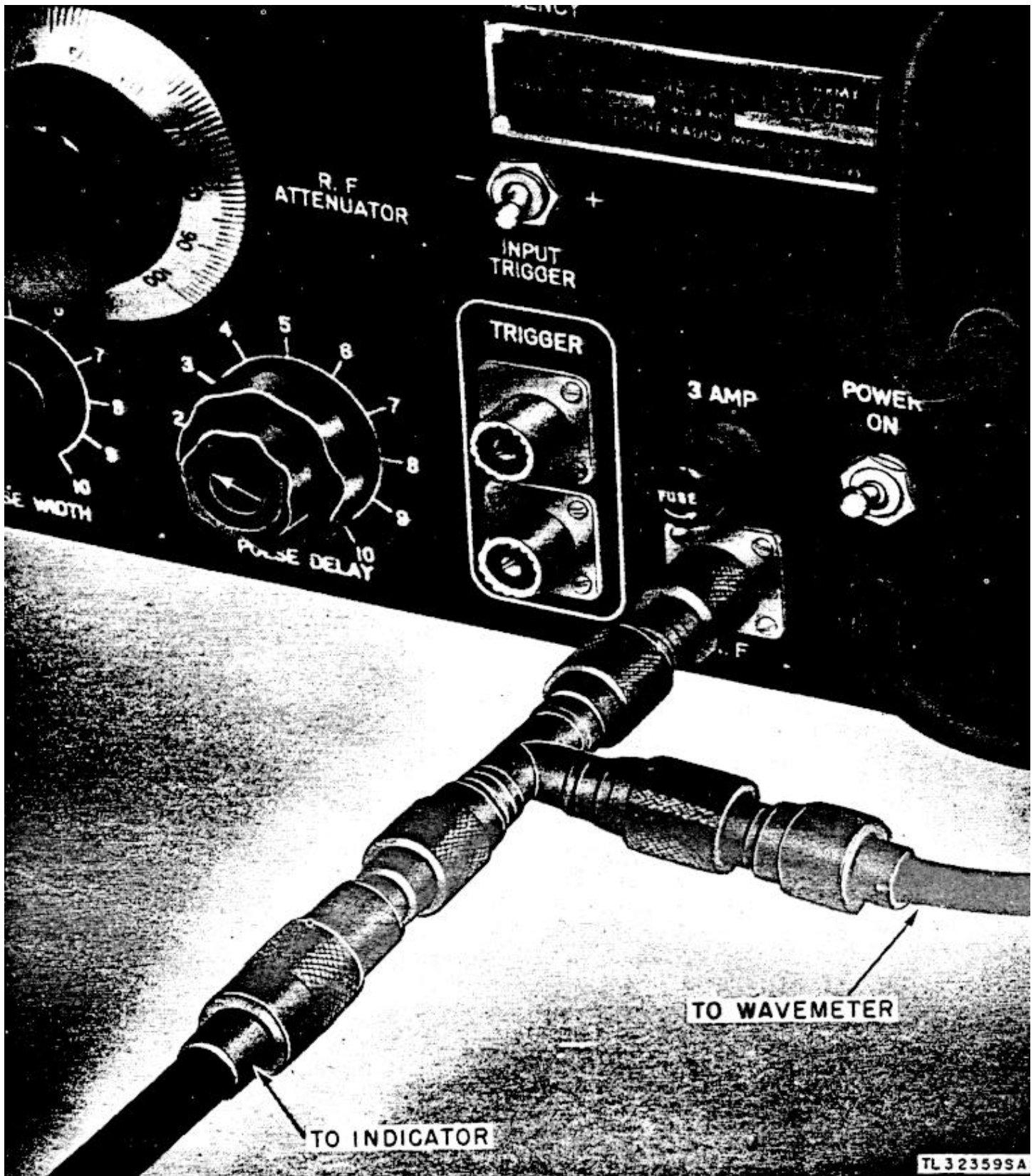

Figure 33. Adapter assembly connected to signal generator

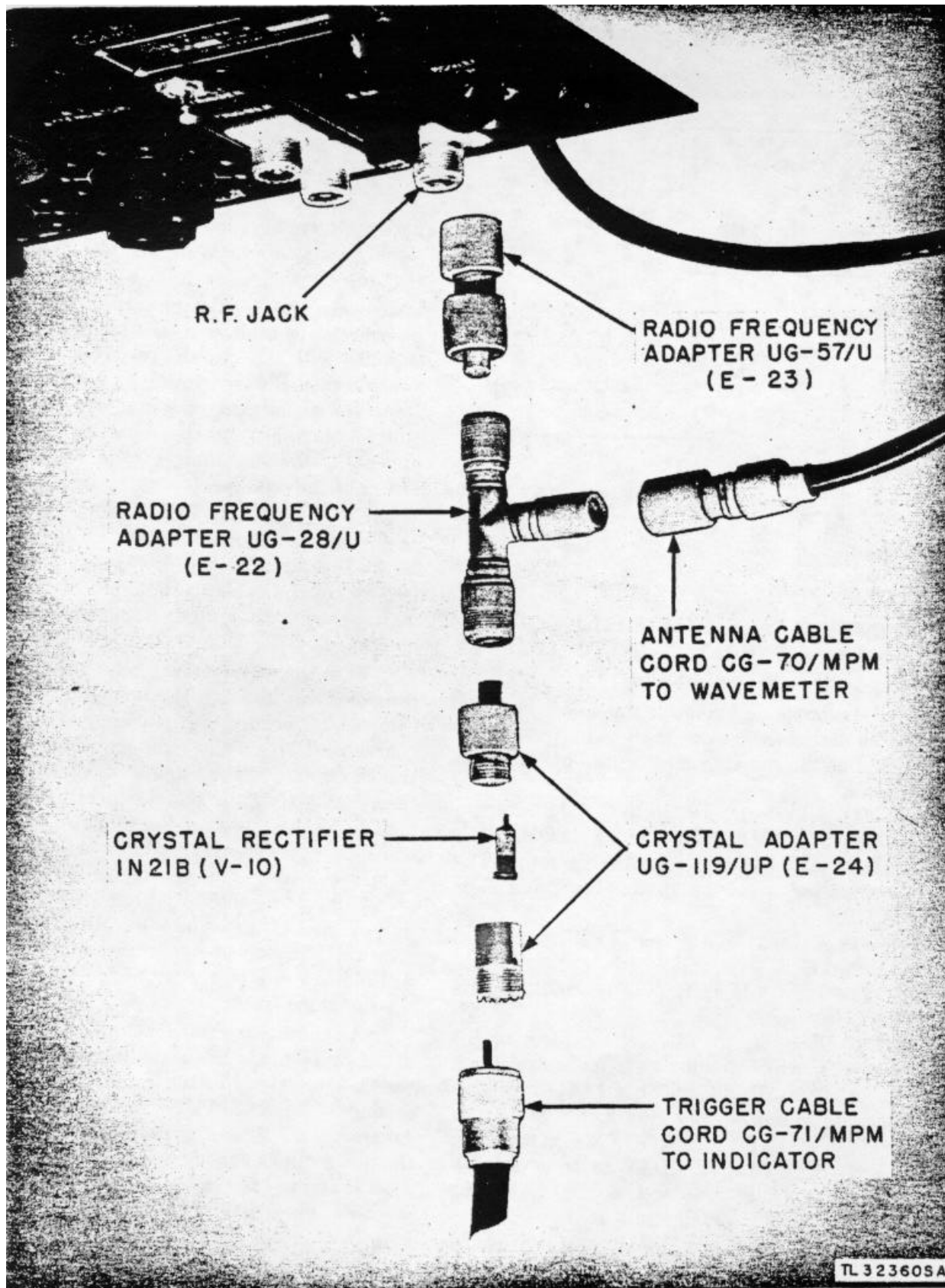

Figure 34. Adapter assembly, exploded view.

(3) If an oscilloscope is used as an indicator, connect Cord CX-145/MPM (trigger cable) between a TRIGGER jack of the signal generator and the synchronizing input terminal of the oscilloscope (fig. 35).

(4) The use of adapter assembly is covered in paragraph 44.1.

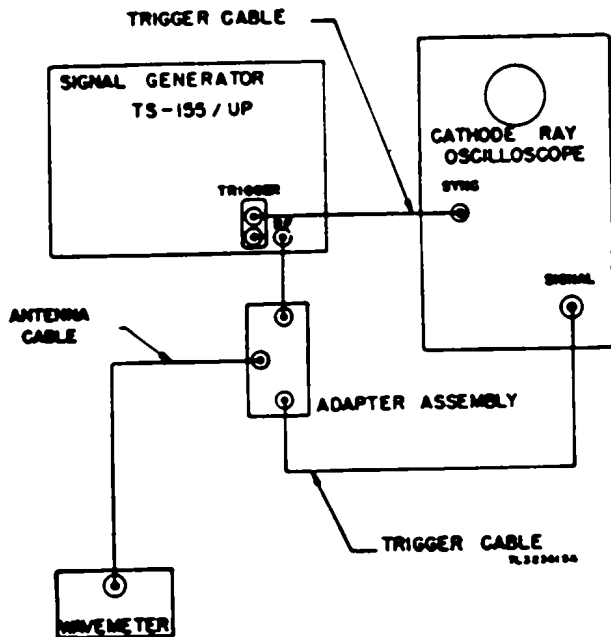

Figure 35. Adapter assembly connection, block diagram

44.1 FREQUENCY CALIBRATION OF SIGNAL GENERATOR USING ADAPTER ASSEMBLY.

(Added.)

a. Assemble and connect the adapter assembly as described in paragraph 44d.

b. Put the signal generator into operation as follows:

- (1) Set selector switch to CALIB.
- (2) Turn OUTPUT TRIG FREQUENCY control to 2,000 on Signal Generator TS-155A/UP or to 10 on Signal Generator TS-155/UP.
- (3) Turn R. F. OSC OUTPUT control to midposition.
- (4) Turn METER ZERO. SET control fully clockwise.
- (5) Turn R. F. TUNING control to the setting for which frequency is to be measured.
- (6) Turn R. F. ATTENUATOR-control clockwise to red reference mark.
- (7) Set INPUT TRIGGER switch to +.

(8) Set PULSE DELAY controls to minimum delay (fully counterclockwise). Set fine PULSE DELAY (small knob) to 3.

(9) Set PULSE WIDTH control to maximum (fully clockwise).

(10) Turn POWER switch to ON and R. F. OSC switch off. Wait 3 minutes for the signal generator to warm up.

(11) Turn METER ZERO SET control until power monitor meter reads zero.

(12) Turn R. F. OSC switch to ON. With R. F. OSC OUTPUT control, set power monitor meter to read 200.

(13) Turn selector switch to INT TRIG.

c. Connect Cord CG-71/MPM (trigger cable) between Crystal Adapter UG-119/UP and the signal input terminals of the test oscilloscope (fig. 35).

d. Start the oscilloscope according to the information contained in the technical manual supplied with it. Set the oscilloscope with its sweep externally synchronized by the trigger from the signal generator and with maximum gain for the input signal. A small pulse should appear at the beginning of the trace on the screen of the oscilloscope.

e. Connect Cord CG-70/MPM (antenna cable) to the tee adapter jack at right angles to the two jacks in line (fig. 35). Connect the free end of the cable to the input of the wavemeter, echo box, or other frequency-measuring device.

f. Turn the wavemeter or echo box frequency control slowly through the range of frequencies believed to include the frequency of the signal generator. When the frequency measured by the wavemeter is the same as the frequency of the r-f output of the signal generator, the amplitude of the pulse on the oscilloscope screen will dip or rise sharply. When the dip or rise is located, tune the wavemeter or echo box about this point carefully to get the maximum dip or rise of the pulse on the oscilloscope screen. The wavemeter or echo box reading will indicate the frequency of the r-f output of the signal generator.

g. A calibration curve for the R. F. TUNING dial may be made by using the wavemeter or echo box to determine the frequency at different settings of the R. F. TUNING dial on the signal generator. The curve obtained by plotting the dial settings against the frequency will give a calibration of the signal generator. Replacement of the oscillator tube or changes in the variables of the cavity will necessitate recalibration of the unit.

AGO 1767A

44.2. THEORY OF OPERATION OF ADAPTER ASSEMBLY. (Added.)

The adapter assembly is made up of standard type-N fittings, a crystal rectifier, and an ultrahigh-frequency (u-h-f) jack. The assembly is essentially a T-section of coaxial line, one leg of which contains a crystal rectifier. Figure 36 shows the equivalent circuit of this arrangement of adapter.

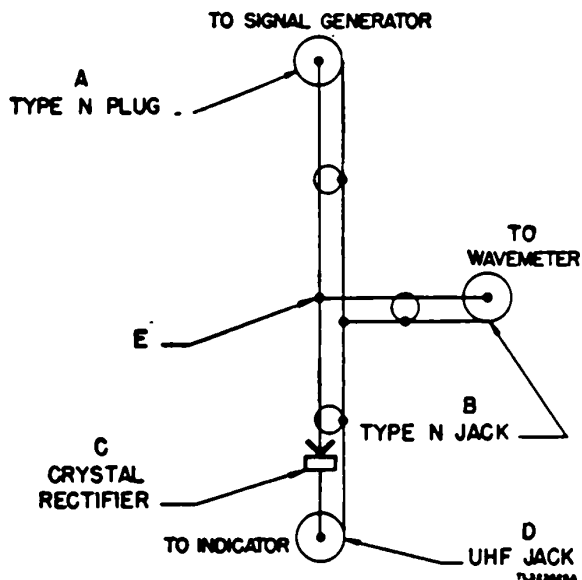

Figure 36. Adapter assembly, schematic diagram

a. When the signal generator is placed in operation with the adapter assembly connected (par. 44d), a fixed amount of power is fed into the type-N plug, A, (fig. 36) of the adapter assembly at the R. F. jack. This power is fed through the coaxial line to the type-N jack, B, and through the coaxial line and crystal rectifier, C, to the u-h-f jack, D. The crystal rectifier converts the r-f pulses into video pulses which can be seen on the test oscilloscope.

b. The distribution of energy (at point E) to the two output lines is determined mainly by the ratios of the impedance of the two output lines. In operation, the line with the crystal rectifier and the oscilloscope (or other indicator) will maintain a constant impedance. The line which is loaded by the wavemeter has a variable impedance. This impedance will remain fairly constant until the wavemeter is set so that its resonant frequency is the same as the input frequency (from the signal generator). The impedance will then undergo a marked change. This affects the impedance ratio between the two output lines and causes a change in the distribution of power to these two lines (at point E). The change in

power distribution changes the power input to the oscilloscope and will be indicated by a rise or dip in the amplitude of the pulse on the oscilloscope screen.

NOTE: It is possible that the combination of the adapter assembly, cables, and wavemeter may be such that no pulse dip or rise occurs at a critical frequency. It is much more probable, when no dip or rise is seen, that the range covered is wrong or that the range was covered too quickly and the dip or rise not noticed. To eliminate the possibility of no dip or rise appearing because of the combination of parts, check the apparatus at a different frequency setting.

44.3. PREVENTIVE MAINTENANCE RFO ADAPTER ASSEMBLY. (Added.)

Remove all dirt and dust from the adapter assembly with a clean cloth. Crystal rectifiers 1N21B, when not installed in the crystal adapter, should be kept in the lead shielding jackets.

44.4. TROUBLE SHOOTING ADAPTER ASSEMBLY. (Added.)

The two troubles which may occur in the adapter assembly, aside from breakage, are a burned-out crystal or an adapter failing to make contact. Loose contacts may be tightened easily and a burned-out crystal replaced.

a. *Check for Burned-out Crystal.* The simplest test for a faulty crystal is substitution of a spare crystal which is known to be in good condition. The crystal may be checked also with an ohmmeter. The resistance measured in the two directions through the crystal will be nearly equal in a burned-out crystal and in approximately 5-to-1 ratio or higher for a good crystal.

b. *Replacement of Crystal.* To install a new crystal rectifier in Crystal Adapter UG-119/UP, unscrew the two parts of the crystal adapter. Remove the spare crystal rectifier from its container and insert it, small diameter end first, in the inner portion of the half of Crystal Adapter UG-119/UP containing the type-N plug. The crystal rectifier will fit firmly into the fingers in the adapter. Screw down the other part of the crystal adapter until a positive contact is made.

44.5. DISASSEMBLY OF CAVITY (figs. 37 to 41).

(Added.)

a General

(1) The cavity should not be disassembled except for replacement of the r-f oscillator tube (8) or the thermistors (42, 43). Instructions for these replacement procedures are contained in paragraphs 43b and 43c. By looking into the cavity when the tailpiece (2) is removed, it is possible to observe the condition of the plate cap fingers (17) and of that portion of the plate tuning shaft on which the inner ring of fingers of the plunger slides.

CAUTION: If the tailpiece (2) is to be removed and replaced, the grid leak housing (14) must first be unthreaded and removed; otherwise, the grid leak sleeve assembly will be damaged.

(2) If the cavity is defective, it should be returned to the factory. Emergence conditions, however, may necessitate repairs at a repair base. The following instructions are therefore supplied. These instructions apply to the "PR" type cavity. Refer to paragraph 43a for the structural differences between the "PR" and the "AO" type cavities.

(3) Read paragraphs 31 and 32 for a description of the cavity and associated parts. Refer to figures 37 through 41 for removal of the oscillator cavity and associated assemblies.

(4) The following is a key to figures 37 to 41, inclusive:

1. Adjusting screw.
2. Tailpiece.
3. R-f chokes.
4. Heater.
5. Cathode.
6. Tailpiece clamp.
7. Tailpiece clamp screw.
8. Oscillator tube (type 446B or 2C40).
9. Cathode ring.
10. Cathode fingers.
11. Grid ring.
12. Grid fingers.
13. Grid cylinder sleeve assembly.
14. Grid leak and housing.
15. Plate cap.
16. Split cylinder, outer ring contact fingers.
17. Plate cap fingers.

18. Plunger rack.
19. Plunger.
20. Plunger gear.
21. Plunger gear housing.
22. Plunger gear locking screw.
23. Cap nut.
24. Slot for screwdriver adjustment.
25. Worm.
26. Front clamp screw.
27. Front lamp.
28. Plate tuning shaft assembly.
29. Sliding drive yoke.
30. Collector ring.
31. Lockscrew.
32. Stop.
33. Shaft to tuning dial.
34. Brush.
35. Brush mounting block.
36. Thermistor coupling loop.
37. Attenuator mounting screws.
38. Thermistor connecting link.
39. Soldered connection.
40. Thermistor assembly mounting screws.
41. Thermistor housing.
42. Disk thermistor.
43. Bead thermistor.
44. Brass disk.
45. Securing nut.
46. Tapered brass rod.
47. Brass rod.
48. Terminal post.
49. Limit screw.
50. Guide rod.
51. Rack.
52. Attenuator loop.
53. Spring fingers.
54. Attenuator tube.
55. Support block.
56. Clamping screw.
57. Coupling to attenuator dial shaft.
58. Gear.
59. Attenuator piston.
60. Insulated brass rod.
61. Attenuator jack.
62. Adjusting screw.
63. Allen setscrew wrenches.
64. Oscillator cavity.

65. Tuning shaft setscrews.
66. Plate lead.
67. Coupling setscrews.
68. Attenuator dial shaft.
69. Attenuator dial shaft setscrews.
70. Attenuator cable connection.
71. Attenuator cable.
72. R-f jack.
73. Support block mounting screws.
74. Tailpiece clamp mounting screws.
75. Front clamp mounting screws.

reassembled in the cavity. This procedure is necessary to prevent damage to the grid cylinder sleeve assembly (13) and to the grid lead.

(3) Turn the tuning dial fully counterclockwise. This moves the plate cap fingers (17) to a position close to the end of the plate cap (15) of the tube and minimizes the possibility of breaking the tube when it is removed.

(4) Loosen the tailpiece adjusting screw (1). (In the "AO" type cavity it is necessary

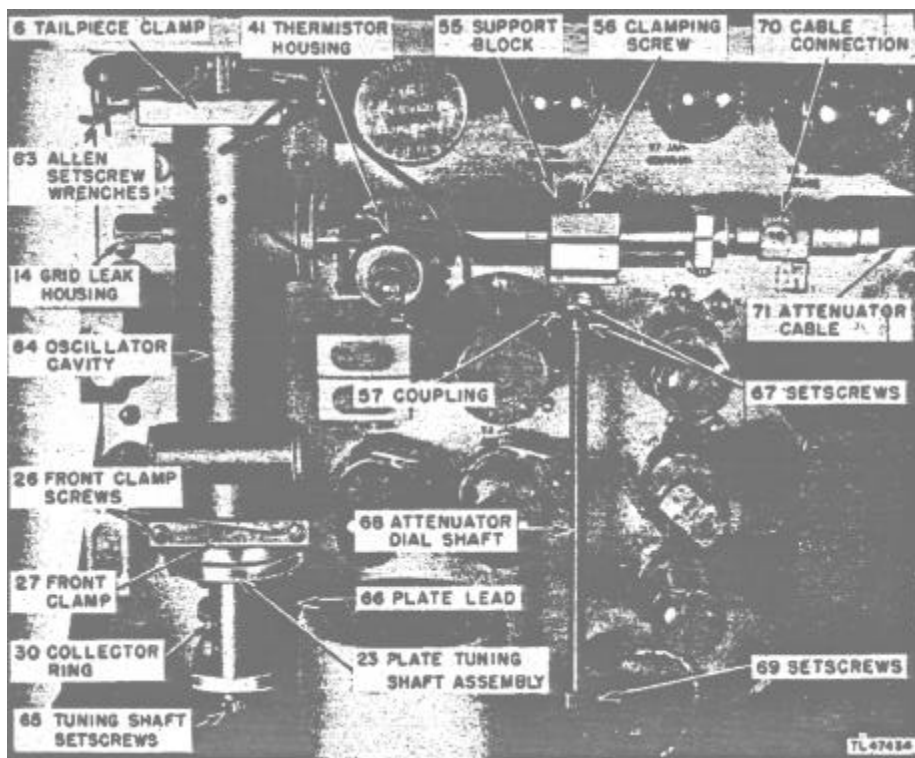

Figure 37. Oscillator assembly mounted on sign generator chassis.

b. *Removal of Tailpiece and Type 446B or 2C40 Oscillator Tube.* Access to the oscillator tube (8) and to the filament cathode chokes (3) is gained by removal of the tailpiece (2):

(1) Turn the POWER switch and the R. F. OSC switch off and disconnect the power cord from the main source.

(2) Remove the grid leak housing (14) from the cavity.

CAUTION: Remove the grid leak housing (14) before removing the tailpiece. Do not replace the grid leak housing and grid leak until the tailpiece has been permanently to

remove the six screws that hold the tailpiece in the cavity.)

(5) Disconnect the cathode and heater leads from the tailpiece and tag them.

(6) Loosen the tailpiece clamp screw (7).

(7) Withdraw the tailpiece by rotating it slightly and pulling backwards.

c. *Removal of Oscillator and Attenuator Assemblies from Chassis of Signal Generator.* Before proceeding further with the disassembly of the cavity it is necessary to remove the entire assembly from the signal generator.

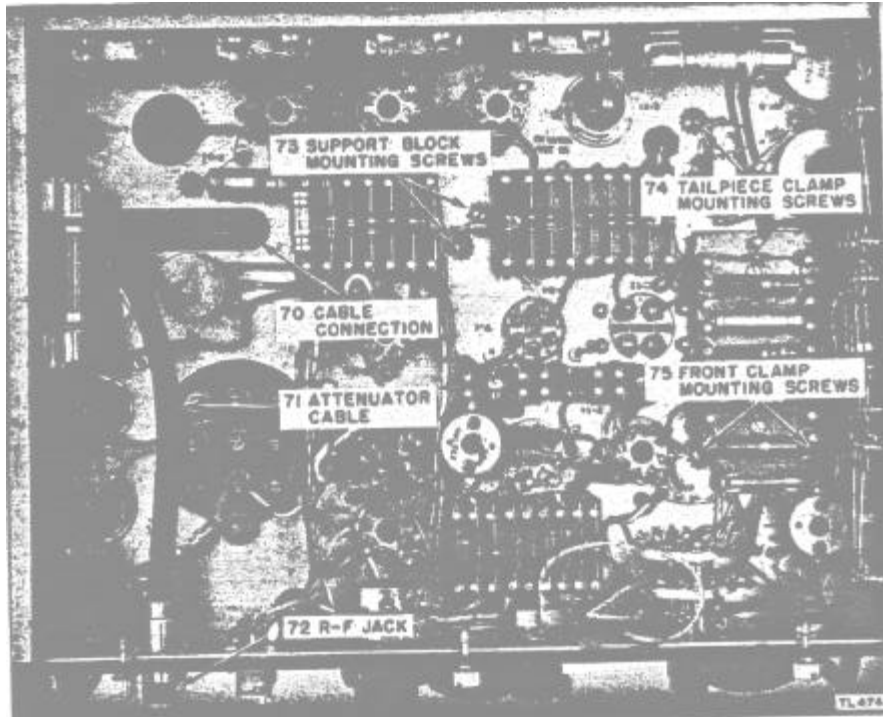

Figure 38. Bottom of chassis, oscillator assembly mounting screws..

(1) Disconnect the attenuator cable connection (70).

(2) Unsolder and remove all thermistor terminal connections. Tag all leads to facilitate location during reassembly.

(3) Disconnect the plate lead (66) on the brush mounting block (35).

(4) Loosen the r-f tuning shaft setscrews (65) and setscrews (67) at the coupling to the attenuator dial shaft (68).

(5) While supporting the cavity assembly, remove the support block mounting screws (73) on the bottom of the chassis.

(6) Support the cavity assembly. Remove the tailpiece clamp mounting screws (74) and front clamp mounting screws (75) on the bottom of the chassis.

(7) Free the oscillator cavity and associated assemblies and remove from the signal generator chassis.

d. *Disassembly of Attenuator* (fig. 39). Remove the four attenuator mounting screws (37) that fasten the attenuator to the oscillator cavity. Separate the attenuator from the cavity.

(1) Remove the limit screw (49) and withdraw the attenuator piston (59) from the attenuator tube (54) by turning the coupling to the attenuator dial shaft (57) counterclockwise.

(2) The support block (55) may be removed from the attenuator tube (54) by loosening the clamping screw (56).

CAUTION:

1. Do not change the setting of the adjusting screw (62), or the calibration of the unit may be destroyed.

2. The lead from the thermistor coupling loop (36) is soldered (39) to the lead from the bead thermistor. This connection will be broken if the thermistor assembly mounting screws (40) are removed and the thermistor assembly separated from the attenuator assembly.

e. *Disassembly of Thermistor Unit.* Removal and replacement of the bead and disk thermistors is described in paragraph 43c.

f. *Removal of Plate Tuning Shaft Assembly from Oscillator Cavity* (figs. 39 and 40). To remove the plate tuning shaft assembly (28) from the oscillator cavity proceed as follows:

(1) Remove the two screws holding the brush mounting block (35) in place.

AGO 1767A

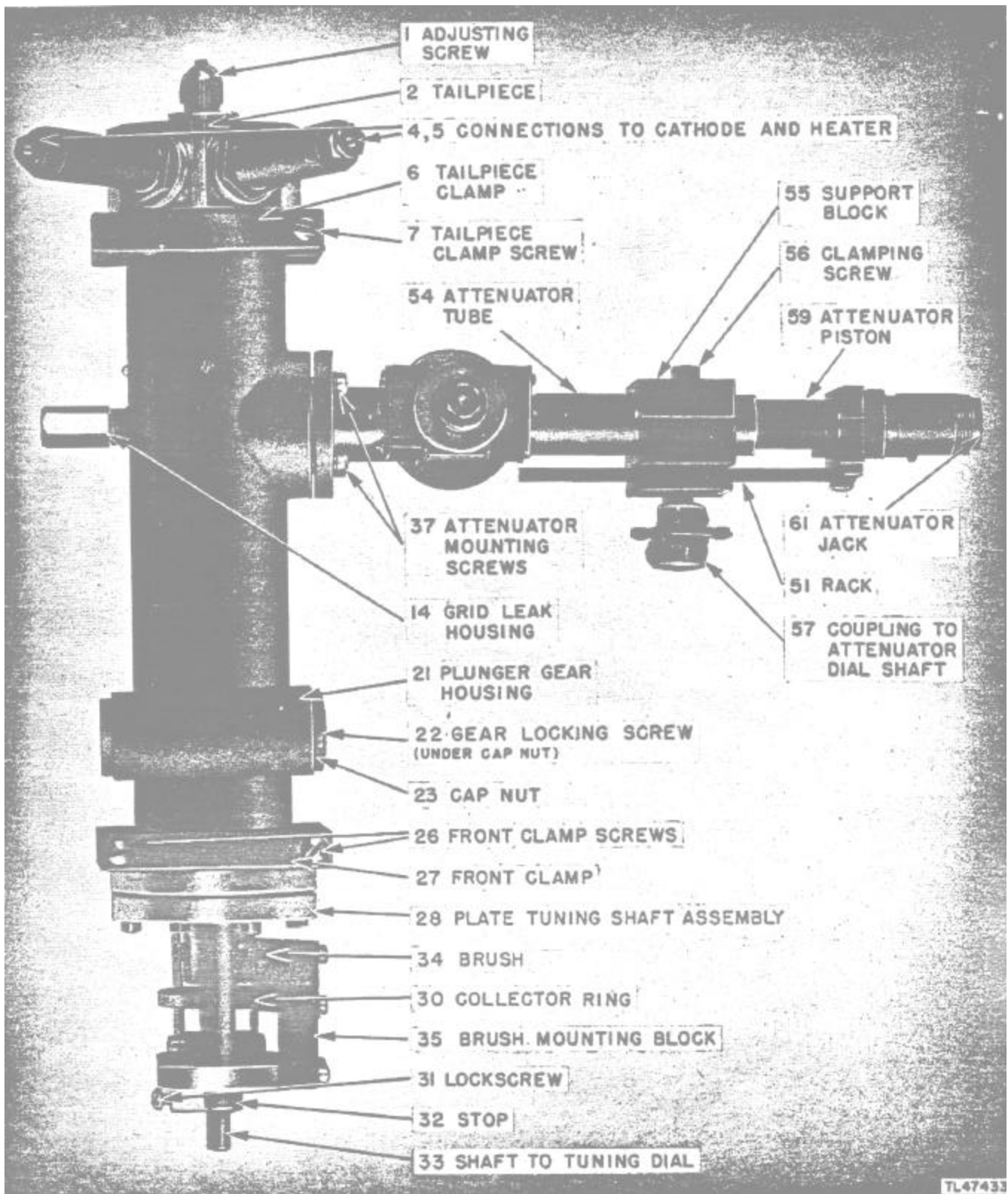

Figure 39. Oscillator assembly removed from signal generator chassis.

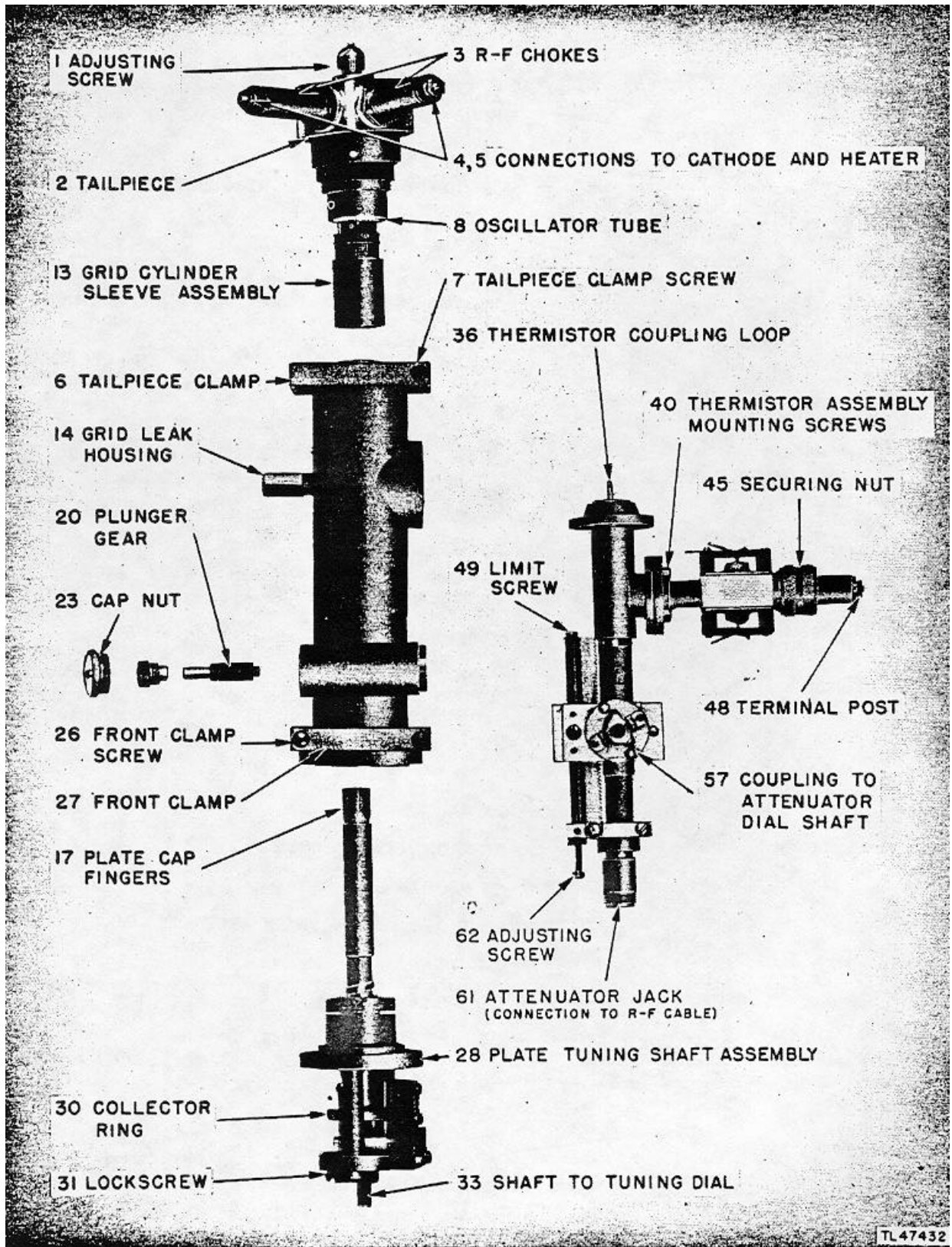

Figure 40. Oscillator assembly, exploded view.

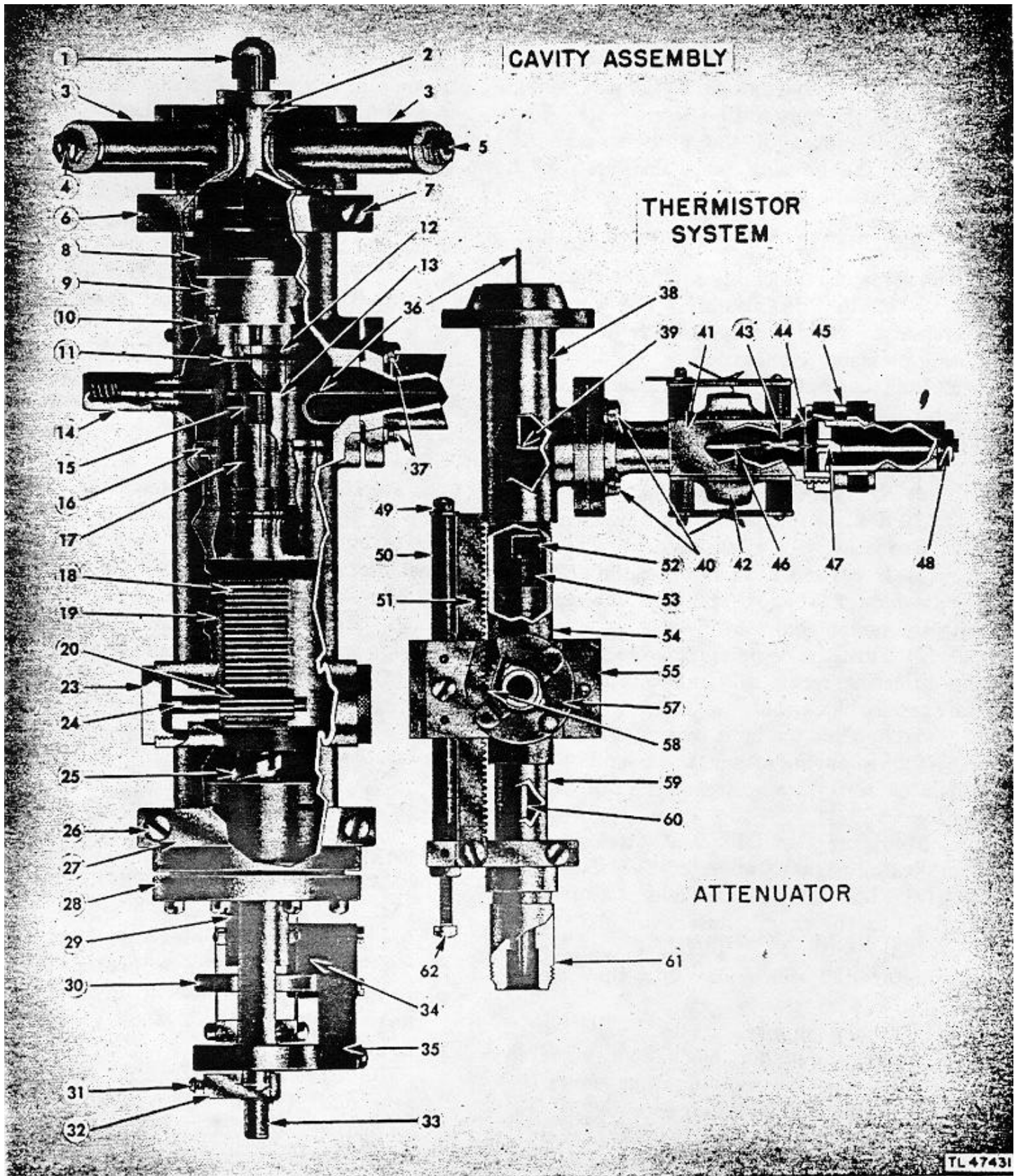

Figure 41. Oscillator assembly, cut-away view.

(2) Remove the eight screws holding the plate tuning shaft assembly (28) in the cavity.

(3) Carefully withdraw the tuning assembly from the cavity.

CAUTION:

1. **Do not loosen the lock screw (31) on the tuning shaft stop (32), or the calibration of the unit will be destroyed.**

2. **Removal of the plunger gear (20) from the housing may also destroy the calibration.**

44.6. REASSEMBLY OF CAVITY. (Added.)

The steps in reassembly are in each case the reverse of the disassembly. Care must be exercised to avoid damage to any of the parts during reassembly operations.

a. Replacement of Plate Tuning Shaft Assembly.

(1) Insert the plate tuning shaft assembly (28) into the oscillator cavity.

(2) Replace the eight holding screws.

(3) Replace the brush mounting block (35).

b. Reassembly of Attenuator.

(1) Insert the attenuator piston (59) into the attenuator tube (54) and mesh the rack (51) with the pinion gear (58).

(2) Turn the coupling (57) clockwise until the adjusting screw (62) makes contact with the support block (55).

(3) Replace the limit screw (49).

(4) Fasten the attenuator assembly to the oscillator cavity by means of the four mounting screws (37).

c. Mounting Oscillator and Attenuator Assemblies on Signal Generator Chassis

(1) Place the oscillator and attenuator assemblies on the chassis; insert the plate tuning shaft (33) into the R. F. TUNING dial, and the attenuator dial shaft (68) into the coupling (57).

(2) While supporting the cavity assemblies, replace the support block mounting screws (73), the tailpiece clamp mounting screws (74), and the front clamp mounting screws (75).

d. Setting L F. ATTENUATOR Dial.

(1) Turn coupling (57) clockwise until the adjusting screw (62) contacts the support block (55).

(2) Set the R. F. ATTENUATOR dial to the red reference line.

[AG 300.7 (6 Jul 45)]

(3) Tighten the coupling setscrews (67).

(4) If the R. F. ATTENUATOR dial is turned counterclockwise to the limit defined by the limit screw (49), the setting of the dial should be at the red reference line again. Agreement on this check will indicate that the attenuator calibration is unchanged.

e. Setting R. F. TUNING Dial

(1) Turn the r-f tuning shaft (33) to the extreme clockwise position.

CAUTION: Do not loosen the lock screw (31) on the turning shaft stop (32), or the calibration of the unit will be destroyed.

(2) Set the R. F. TUNING dial to 100.

(3) Tighten the tuning shaft setscrews (65).

(4) If the R. F. TUNING dial is turned counterclockwise to its limit position, the dial should be at zero. Agreement on this check will indicate that the oscillator calibration is unchanged.

f. Replacement of Tailpiece and Oscillator Tube. Refer to paragraph 43b for the tailpiece and oscillator replacement procedure and the precautions to be observed.

g. Replacement of Leads.

(1) Reconnect the plate lead (66) on the brush mounting block (35).

(2) Reconnect all thermistor terminal connections.

(3) Reconnect the attenuator cable (70).

NOTE: Position cable under chassis so that it clears the protruding screwdriver adjustment fitting.

45. MAINTENANCE PARTS LIST FOR SIGNAL GENERATORS TS-155/UP AND TS-155A/UP.

The following information was compiled on 23 May 1945. The appropriate pamphlets of the ASF Signal Supply Catalog for Signal Generators TS-155 UP and TS-155A/UP are:

SIG 7-TS-155/UP, Organizational Spare Parts.

SIG 8-TS-156/UP, Higher Echelon Spare Parts.

For an index of available catalog pamphlets, see the latest issue of ASF Signal Supply Catalog SIG 2.

* * * *

BY ORDER OF THE SECRETARY OF WAR:

OFFICIAL:
EDWARD F. WITSELL
Major General
Acting The Adjutant

G. C. MARSHALL
Chief of Staff

DISTRIBUTION:

AAF (5); AGF (5); ASF (2); T of Opn (5); Dept (2); Base Comd (2); Island Comd (2); Arm & Sv Bv (1); S Div ASF (1);
Tech Sv (2); SVC (2); Dep 11 (2); Lab 11 (2); 4th & 5th Echelon Maint Shops 11 (2); Three (3) copies to each of
the following: T/O & E 11-107; 11-127; 11-587; 11-592; 11-597.
Refer to FM 21-6 for explanation of distribution formula.

AGO 1767A

U.S. GOVERNMENT PRINTING OFFICE 1945
821--940

SIGNAL GENERATORS
TS-155/UP AND TS-155A/UP

TM 11-2657, Signal Generators TS-155/UP and TS-155A/UP, is published for the information and guidance of all concerned.

[A.G 300.7 (6 January 45)]

BY ORDER OF THE SECRETARY OF WAR:

G. C. MARSHALL,
Chief of Staff.

OFFICIAL:

J. A. ULIO,
Major General,
The Adjutant General.

DISTRIBUTION:

AAF (2); AGF (2); ASF (2); T of Opn (2); Dept (2); Def Comd (2); Arm & Sv Bd (2); S Div ASF (1); Tech Sv (2); SvC (2); PE (2); Gen Overseas SOS Dep (Sig Sec) (2); Dep 11 (2); Rep Shops 11 (2); ASF Dep (Sig Sec) (2); Insp Z 11 (2); Pro Dist 11 (2); Gen & Sp Sv Sch (2); USMA (2); WDGS Lib (5); Lab 11 (2); A (2); T O & E 4-232 (3); 4-240 (3); 4-260-1 (10); Three (3) copies to each of the following: 11-107, 11-127, 11-237, 11-587, 11-592, 11-597, 11-617, 44-16, 44-17, 44-116, 44-117, 44-138.

(For explanation of symbols see FM 21-6.)

TABLE OF CONTENTS

			<i>Paragraph</i>	<i>Page</i>
PART ONE. Introduction.				
SECTION	I.	Description of Signal Generators TS-155/UP and TS-155A/UP.		
		General	1	1
		Nomenclature.....	2	1
		Application	3	1
		Technical characteristics of Signal Generator TS-155/UP.....	4	2
		List of components	5	3
		Differences in models.....	6	4
	II.	Installation and assembly of Signal Generator TS-155/UP		
		Unpacking	7	6
		Location of equipment	8	6
		Dipole antenna installation.....	9	6
		Connection to directional coupler.....	10	7
PART TWO. Operating instructions				
SECTION	III.	Preoperational procedures.		
		Operating controls	11	8
		Connections	12	9
		Starting procedure	13	10
	IV.	Operation.		
		Synchronization.....	14	10
		Testing over-all performance of radar system.....	15	10
PART THREE. Preventive maintenance.				
SECTION	V.	Preventive maintenance techniques		
		Meaning of preventive maintenance.....	16	18
		Description of preventive maintenance techniques.....	17	18
	VI.	Itemized preventive maintenance.		
		Introduction	18	19
		Common materials needed.....	19	19
		Item 1, exterior of Signal Generator TS-155/UP	20	19
		Item 2, top of chassis	21	20
		Item 3, bottom of chassis.....	22	21
		Item 4, Antenna Cable CG-70 MPM and Trigger Cables		
		CG-71 MPM and CX-145 MPM	23	22
		Item 5, Antenna Assembly AS-23/AP	24	22
		Item 6, transit case	25	22
		Preventive maintenance check list	26	22

TABLE OF CONTENTS

			<i>Paragraph</i>	<i>Page</i>
SECTION VII.	Lubrication.			
	Lubrication information			22
VIII.	Moistureproofing and fungiproofing.			
	General	28		23
	Treatment.....	29		23
	Step-by-step instructions for treating Signal Generator TS-155/UP.....	30		23
PART FOUR. Auxiliary equipment.				
Not used.				
PART FIVE. Repair instructions.				28
SECTION IX.	Theory of operation.			
	General description	31		28
	Description of mechanism of cavity and associated parts	32		29
	Analogy of cavity OSC to lumped circuit OSC.....	33		32
	Electrical description of components	34		34
	Functioning of signal generator circuits.....	35		41
	Functioning of signal generator in testing radar systems.....	36		43
X.	Trouble-shooting procedures.			
	Principal parts of test set	37		45
	Access to parts for maintenance.....	38		45
	Pulsing and internal trigger circuits	39		46
	Thermistor bridge monitoring system.....	40		47
	Attenuator cable	41		47
	Test analysis data.....	42		47
	Mechanical repairs	43		49
	Adjustments	44		52
APPENDIX.	Maintenance parts list for Signal Generators TS-155/UP and TS-155A/UP			55

LIST OF ILLUSTRATIONS

<i>Fig. No.</i>	<i>Title</i>	<i>Page</i>
1	Signal Generator TS-155/UP	x
2	Antenna Assembly AS-23/AP.....	3
3	Cavities for Signal Generators TS-155/UP and TS-155A/UP	5
4	Signal Generator TS-155/UP used with a pick-up dipole	6
5	Signal Generator TS-155/UP used with directional coupler.....	7
6	Signal Generator TS-155/UP, operating controls.....	8
7	Coarse PULSE DELAY control settings.....	9
8	OUTPUT TRIG FREQUENCY control settings for TS-155/UP	9
9	PULSE WIDTH control settings	9
10	Top of chassis	20
11	Bottom of chassis	21
12	Masking, top of chassis	24
13	Masking, bottom of chassis	25
14	Signal Generator TS-155/UP, block diagram	28
15	Disassembled cavity.....	30
16	Schematic diagram of cavity	33
17	Equivalent circuit of cavity	33
18	Basic blocking oscillator circuit.....	34
19	Blocking oscillator waveforms	34
20	Blocking oscillator circuit	34
21	Cathode-follower circuit.....	35
22	Delay multivibrator circuit	36
23	Waveforms	37
24	Differentiator circuit	38
25	Pulse multivibrator circuit	38
26	Pulse modulator circuit	38
27	Thermistors	39
28	Thermistor bridge circuit.....	40
29	Signal Generator TS-155/UP, complete schematic diagram	42
30	Signal Generator TS-155/UP, operation with radar set.....	44
31	Test set signal on A-, PPI, and B-scopes.....	45
32	Calibration of Signal Generator TS-155/UP with Wavemeter Test Set TS-117/GP	53

DESTRUCTION NOTICE

- WHY** - To prevent the enemy from using or salvaging this equipment for his benefit
- WHEN** - When ordered by your commander.
- HOW** -
1. Smash - Use sledges, axes, hand axes, pickaxes, hammers, crowbars, heavy tools.
 2. Cut - Use axes, hand axes, machetes.
 3. Burn - Use gasoline, kerosene, oil, flame throwers, incendiary grenades
 4. Explosives - Use firearms, grenades, TNT.
 5. Disposal - Bury In slit trenches, fox holes, other holes. Throw in streams. Scatter.

USE ANYTHING IMMEDIATELY AVAILABLE FOR DESTRUCTION OF THIS EQUIPMENT.

- WHAT** -
1. Smash - Meter, knobs, switches, cavity, thermistor, r-f plumbing, and all tubes.
 2. Cut - Cables and wiring.
 3. Burn - Technical manuals, schematic diagrams, cables, and wiring.
 4. Bend - Panels and chassis.
 5. Bury or scatter - All of the above pieces after destroying their usefulness.

DESTROY EVERYTHING

WARNING

HIGH VOLTAGE

is used in the operation of the signal generator and the components of the radio equipment with which the test equipment is used.

DEATH ON CONTACT

may result if personnel fail to observe safety precautions.

BE CAREFUL TO AVOID CONTACT WITH HIGH-VOLTAGE CIRCUITS OR 115-VOLT A-C INPUT CONNECTIONS WHILE CHECKING OR SERVICING THE RADIO EQUIPMENT. MAKE CERTAIN THAT THE POWER IS TURNED OFF BEFORE DISASSEMBLING THE SIGNAL GENERATOR TO PERFORM MAINTENANCE.

FIRST AID TREATMENT FOR ELECTRIC SHOCK

I. FREE THE VICTIM FROM THE CIRCUIT IMMEDIATELY.

Shut off the current. If this is not immediately possible, use a dry nonconductor (rubber gloves, rope, board) to move either the victim or the wire. Avoid contact with the victim. If necessary to cut a live wire, use an ax with a dry wooden handle. Beware of the resulting flash.

II. ATTEND INSTANTLY TO THE VICTIM'S BREATHING.

Begin resuscitation at once on the spot. Do not stop to loosen the victim's clothing. Every moment counts. Keep the patient warm. Wrap him in any covering available. Send for a doctor. Remove false teeth or other obstructions from the victim's mouth.

Resuscitation

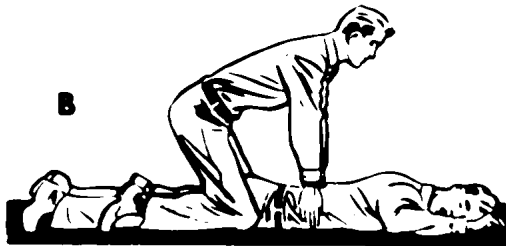

POSITION

1. Lay the victim on his belly, one arm extended directly overhead, the other arm bent at the elbow, the face turned outward and resting on hand or forearm, so that the nose and mouth are free for breathing (fig. A).
2. Straddle the patient's thighs, or one leg, with your knees placed far enough from his hip bones to allow you to assume the position shown in figure A.
3. Place your hands, with thumbs and fingers in a natural position so that your palms are on the small of his back, and your little fingers just touch his lowest ribs (fig. A).

FIRST MOVEMENT

4. With arm held straight, swing forward slowly so that the weight of your body is gradually brought to bear upon the victim. Your shoulders should be directly over the heels of your hands at the end of the forward swing (fig. B). Do not bend your elbows. The first movement should take about 2 seconds.

SECOND MOVEMENT

5. Now immediately swing backward, to remove the pressure completely (fig. C).
6. After 2 seconds, swing forward again. Repeat this pressure-and-release cycle 12 to 15 times a minute. A complete cycle should require 4 or 5 seconds.

CONTINUED TREATMENT

7. Continue treatment until breathing is restored or until there is no hope of the victim's recovery. Do not give up easily. Remember that at times the process must be kept up for hours.
8. During artificial respiration, have someone loosen the victim's clothing. Wrap the victim warmly; apply hot bricks, stone, etc. Do not give the victim liquids until he is fully conscious. If the victim must be moved, keep up treatment while he is being moved.
9. At the first sign of breathing, withhold artificial respiration. If natural breathing does not continue, immediately resume artificial respiration.
10. If operators must be changed, the relief operator kneels behind the person giving artificial respiration. The relief takes the operator's place as the original operator releases the pressure.
11. Do not allow the revived patient to sit or stand. Keep him quiet. Give hot coffee or tea, or other internal stimulants.

HOLD RESUSCITATION DRILLS REGULARLY

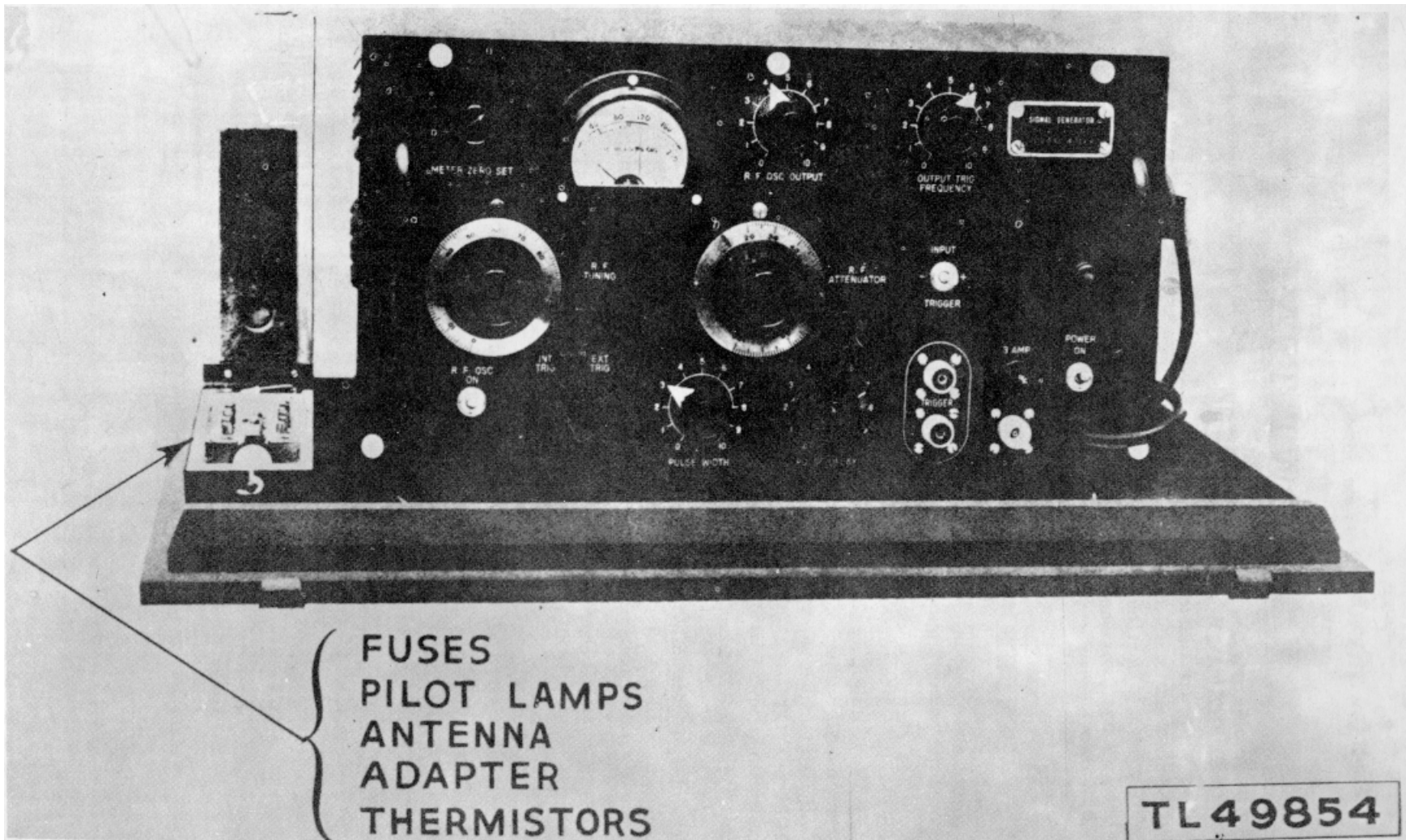

Figure 1. Signal Generator TS-155/UP

X

PART ONE

INTRODUCTION

SECTION I.- DESCRIPTION OF SIGNAL GENERATORS TS-155/UP and TS-155A/UP

1. GENERAL

Signal Generator TS-155/UP (fig. 1) is a generator of pulse-modulated, calibrated, radio-frequency (r-f) signals. It is used for testing the operation of radar sets in the band of frequencies from 2,700 to 2,900 megacycles per second. As a signal generator it measures or checks the sensitivity of the radar receiver; as an r-f wattmeter it measures or checks the power output of the radar transmitter.

2. NOMENCLATURE.

The nomenclature Signal Generator TS-155/UP is used in this manual to indicate Signal Generator TS-155/UP and Signal Generator TS-155A/UP. Signal Generator TS-155A/UP is mentioned specifically when it differs from Signal Generator TS-155/UP.

3. APPLICATION.

The signal generator may be used in any of the following ways:

a. As a pulsed signal generator pulse-modulated by an internal pulse generator. The pulse characteristics such as pulse width, pulse delay, and pulse frequency, are continuously variable over a limited range.

b. As a pulsed signal generator triggered from an external source. A trigger inverter is supplied to permit the use of either positive or negative triggers. Pulse width and pulse delay are variable as in subparagraph a above.

c. As a source of monitor pulses. The signal generator contains a special monitoring pulse circuit which provides a pulse of fixed length and fixed repetition

frequency of approximately 650 cycles per second (approximately 800 cycles per second for Signal Generator TS-155A/UP). These special pulsing characteristics are used in order to adjust the oscillator tube voltage to correspond to reference levels of r-f power. The length of this pulse is factory-adjusted so that a known amount of peak power is delivered at the r-f jack into a matched load, when the average power output is standardized.

d. As a power monitor. A thermistor connected in one arm of a Wheatstone bridge is mounted directly in the r-f line between the cavity and attenuator so as to absorb a constant fraction of the power generated by the oscillator. The resistance of the thermistor arm of the bridge varies with the r-f power flowing in the thermistor. The corresponding unbalance of the bridge is indicated by the power monitor meter, the readings being directly proportional to the r-f power absorbed by the thermistor.

(1) The r-f power generated by the oscillator is delivered to the R.F. jack through a variable attenuator. When used in conjunction with the power monitor meter, the R.F. ATTENUATOR dial reads peak power directly in decibels below 1 milliwatt over the range, from -20 to -100 dbm (decibels below 1 milliwatt peak power is abbreviated -dbm in this manual).

(2) The power monitor is also capable of measuring the average power from an external source delivered to the R.F. jack. The energy to be measured is delivered to the monitoring system through the attenuator, and the amount is read on the power monitor meter directly in milliwatts.

e. As an uncalibrated absorption type frequency meter. The tunable cavity of the oscillator may serve as the tuned circuit of a frequency meter. The power under test is delivered to the R.F. jack and is coupled to the power monitoring system through the attenuator. When the cavity is tuned through resonance, the power monitor meter reading passes through a minimum. If all cavity adjustments are left unchanged, the signal generator may then be used as an r-f oscillator, generating power at a frequency close to that of the external source used to tune the cavity.

4. TECHNICAL CHARACTERISTICS OF SIGNAL GENERATOR TS-155/UP.

Input power..... As connected at the factory:
90 watts.
105 to 125 volts.
50 to 800 cycles.

Power transformer reconnected by disconnecting the lead from the 115 terminal and connecting it to the 230 terminal.
90 watts.
210 to 250 volts.
50 to 800 cycles.

Output.

R-f frequency 2,700 to 2.900 megacycles.

Standard output.....Approximately 650-cycle trigger frequency (approximately 800-cycle trigger on TS 155A/UP). Pulse width adjusted at the factory to permit the R.F. ATTENUATOR dial settings of 20 and above to read peak power output at the R.F. jack in decibels below 1 milliwatt with an accuracy of ± 1 db, when the output impedance is 50 ohms resistive.

Internally synchronized.

Trigger frequency 120 to 2,000 cycles

Pulse width..0.75 to 6.0 microseconds at half amplitude and at a repetition rate of approximately 2,000 cycles. Width is continuously variable.

Pulse delay5 to 1,800 microseconds at a repetition rate of approximately 2,000 cycles. Delay is continuously variable.

Pulse shapeEssentially rectangular. 0.25 microsecond rise time from 10 to 90 percent voltage. 0.3 microsecond fall time from 90 to 10 percent voltage.

Externally synchronized.

External trigger requirements.

Trigger frequency 120 to 2,000 cycles.

Width..... 0.5 to 18.0 microseconds measured at half voltage points

Polarity Either positive or negative.

Amplitude 10 to 100 volts. Negative pulses work into an input of less than 47,000 ohms. Positive pulses work into less than 470,000 ohms.

Rise timeLess than 0.2 microsecond rise time to 20 volts.

Pulse width.....Same as internally synchronized output.

Pulse delay.....Same as internally synchronized output.

Pulse shape ...Same as internally synchronized output.

R-f input power measurement..... With the R.F. ATTENUATOR dial set to the calibration reference mark, the power monitor meter will read directly the average r-f power input at the R.F. jack between approximately 20 and 200 milliwatts with an accuracy of ± 1 db at full scale

5. LIST OF COMPONENTS.

a. Equipment Supplied.

Quantity	Name of unit	Dimensions (inches)				Unit weight (lb.)
		Height	Width	Depth	Length	
1	Signal Generator TS-155/UP.	9	17	12 3/4		36.5
1	Antenna Cable CG-70/MPM.				180	1.5
1	Trigger Cable CG-71/MPM.				72	11/16
1	Trigger Cable CX-145/MPM.				360	1.5
1	Adapter (type 'N" jack to SKL female adapter).	5/8	5/8	1 1/2		1/16
1	Antenna Assembly AS-23/AP.	3 3/4	2 1/4	1 1/4		3.5
1	Allen set screw wrench #10 (in instrument).					
1	Allen set screw wrench #8 (in instrument).					
1	Allen set screw wrench #6 (in instrument).					
1	Allen set screw wrench #4 (in instrument).					
1	Transit case (dimensions to edges of box)	25	15 1/4	12 5/8		26.0
	(dimensions to outside of clamps)	26 1/2	16 1/4	12 7/8		

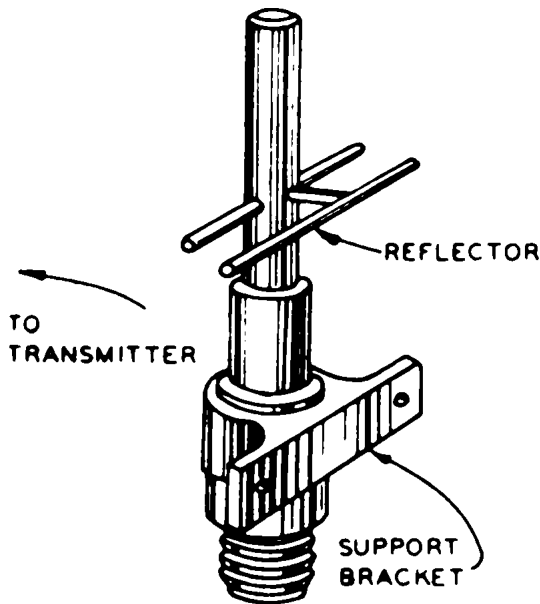

b. *Antenna Assembly AS-23 AP.* The pick-up dipole assembly (fig. 2) consists of two quarter wavelength rods connected to a coaxial line, with a half-wavelength long reflector rod mounted behind the dipole. The coaxial line has a jack (type UG-25 U) that takes a Type "N" plug.

c. *Transit Case.* The transit case consists of a wooden box with handles and a removable cover. The cover contains two compartments for storing the trigger and antenna cables and a copy of this technical manual. The top of the cover contains a felt cushioning strip mounted on a shock absorber, which presses on the top of the signal generator when the cover is closed. The signal generator is mounted on four shock absorbers on the base of the transit case (fig. 1). A small box containing the dipole antenna, the adapter, and the running spares listed in subparagraph d below is mounted on the base alongside the signal generator.

d. *Running Spares.* The running spares listed are for initial use only and are not to be requisitioned as a kit or group as shown in this table.

TL 49855

Figure 2. Antenna Assembly AS-23/AP

Quantity	Name of component	Req'd per unit	Ref. symbols
1	Thermistor (Disk)	1	R40
1	Thermistor (Disk)	1	R39
1	Thermistor (Bead)	1	R35
2	Panel lamp #47	1	I1
5	Fuse 3A	1	F1
5	Fuse 1/32A	1	F2

e. *Tube Complement*

Tube number	Type	Function
V1 A and B	6SN7 GT	Input buffer to delay and pulse multivibrators.
V2 A and B	6SN7 GT	Delay multivibrator.
V3 A and B	6SN7 GT	Pulse multivibrator.
V4	6AG7	Pulse shaper.
V5 A and B	6SN7 GT	Blocking oscillator, cathode follower.
6	OD3/VR-150	Voltage regulator for delay multivibrator.
V7	OC3/VR-105	Voltage regulator for thermistor bridge.
V8	5U4G	Power rectifier.
V9	446B-2C40	R.F. oscillator.

NOTE: Type 446B or 2C40 may be used interchangeably as the R.F. oscillator tube in the signal generator

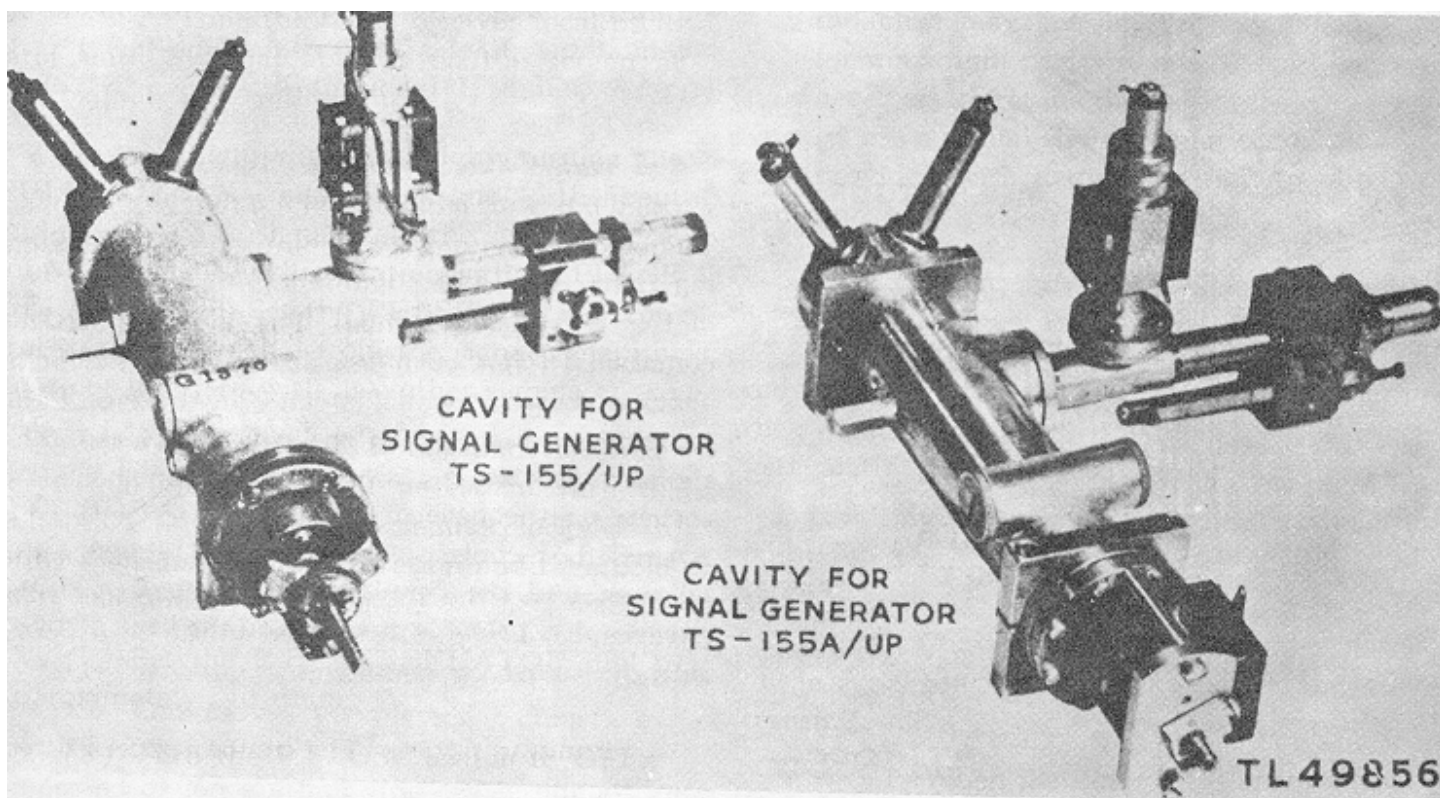

Figure 3. Cavities for Signal Generators TS-155/UP and TS-155A/UP

6. DIFFERENCES IN MODELS.

Signal Generator TS-155/UP differs from Signal Generator TS-155A/UP in several respects. The major differences are in the type of cavity used and in the R.F. ATTENUATOR and R.F. TUNING dials used. Signal Generator TS-155/UP uses a cavity manufactured by Auto Ordnance Company. This cavity is designated "AO" in this manual (fig. 3). Signal Generator TS-155A/UP uses a cavity manufactured by Presto

TS-155/UP

Uses linear or clockwise logarithmic taper potentiometer for OUTPUT TRIG FREQUENCY (P5). (Templetone Part Nos. 650.504A and 650.504C).

C17 is 0.020 mfd.

C7 is 0.001 mfd.

R29 is 4.7 megohms.

P8 is 470 ohms.

P10 is 3300 ohms.

P10 is mounted in left rear corner of chassis;
P8 in front of P10.

Uses some Blocking Oscillator transformers (T1) with winding 3-4 of reversed polarity when compared to TS-155A/UP.

Panel height 8 7/8 inches.

The maintenance parts list (par. 45) contains the maintenance parts for Signal Generators TS-155/UP and TS-155A/UP with the exception of the cavity and the two dials, (R.F. TUNING and R.F. ATTENUATOR) used on

Recording Company. This cavity is designated "PR" in this manual. The differences between the cavities are minor and are outlined in part five, paragraph 43. The cavities are not interchangeable. The R.F. TUNING and R.F. ATTENUATOR dials are single knob vernier type on the TS-155A/UP instead of the type shown in figure 6 as used on the TS-155/UP. The other differences between the TS-155/UP and the TS-155A/UP are listed below.

TS-155A/UP

Uses counterclockwise logarithmic potentiometer for OUTPUT TRIG FREQUENCY (P5) (Templetone part No. 650.504H).

C17 is 0.015 mfd.

C7 is 0.05 mfd.

R29 is 1 megohm.

P8 is 500 ohms.

P10 is 5000 ohms.

P8 is mounted in left rear corner of chassis, P10 in front of P8.

Schematic shows connections for T1 as in TS-155A/UP, and for replacement transformers (T1).

Panel height 9 inches.

Signal Generator TS-155/UP. Inspection of the dials and cavity will quickly indicate the model. Refer to SIG 7 and SIG 8 on Signal Generator TS-155/UP for the stock numbers omitted from this list if they are required.

SECTION II -INSTALLATION AND ASSEMBLY OF

SIGNAL GENERATOR TS-155/UP

7. UNPACKING.

Remove the cover of the transit case. The signal generator may be left attached to the base of the transit case if desired.

8. LOCATION OF EQUIPMENT.

The location of the signal generator with respect to the radar set is critical in only one respect: namely, that the signal generator should be positioned *out of the field* of the radar antenna. Two alternative installation are shown, one where a dipole antenna is used (fig. 4),

and another where a directional coupler is used (fig. 5). These are discussed in the following paragraphs.

9. DIPOLE ANTENNA INSTALLATION (fig. 4).

Connect one end of the Antenna Cable CG-70/MPM to the Antenna AS-23/AP and connect the other end to the R.F. jack on the front panel of the signal generator. It is important that the dipole antenna be located at the same distance from the radar antenna in all tests and that it be placed in the center of the radar antenna beam. It should be located as shown and in

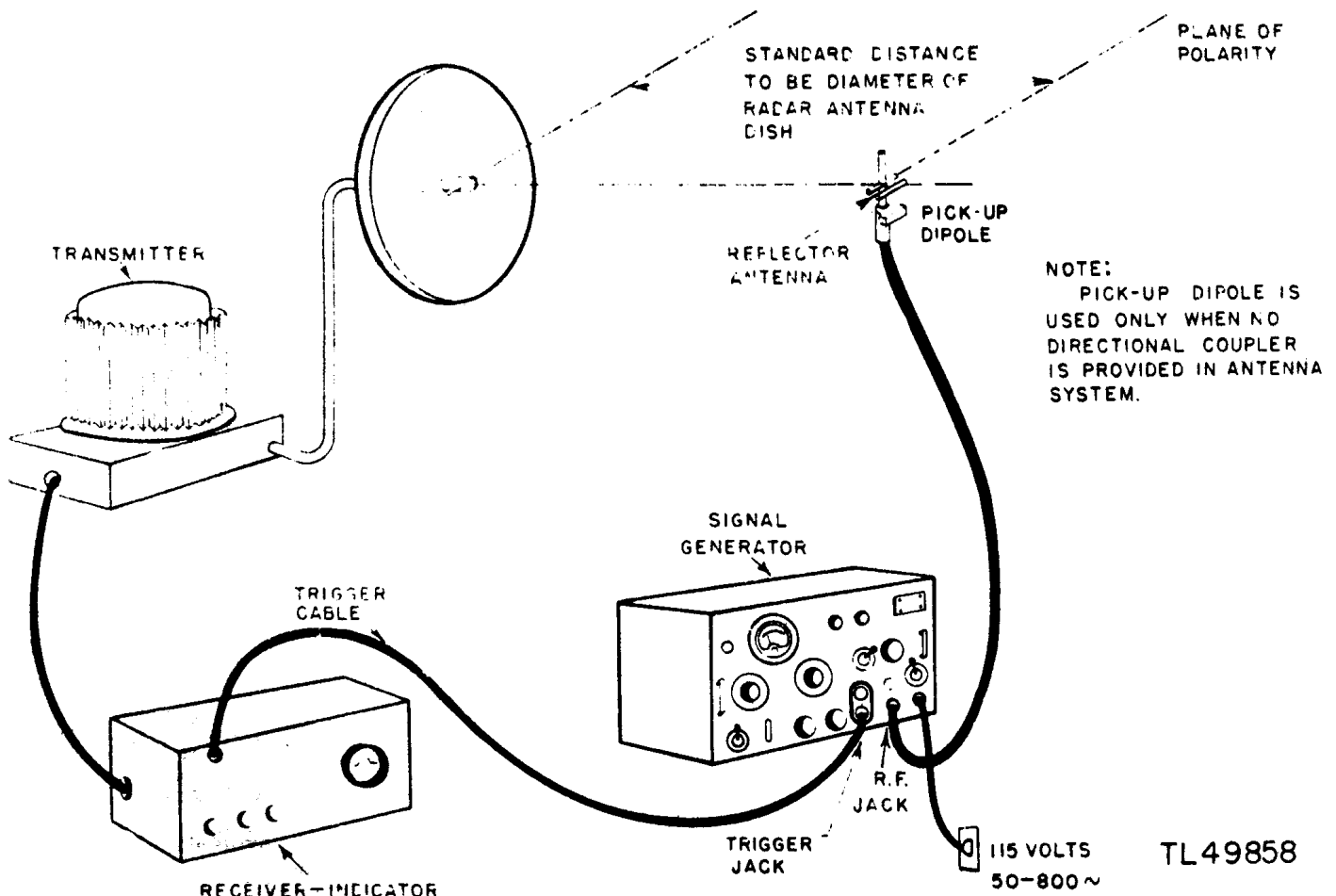
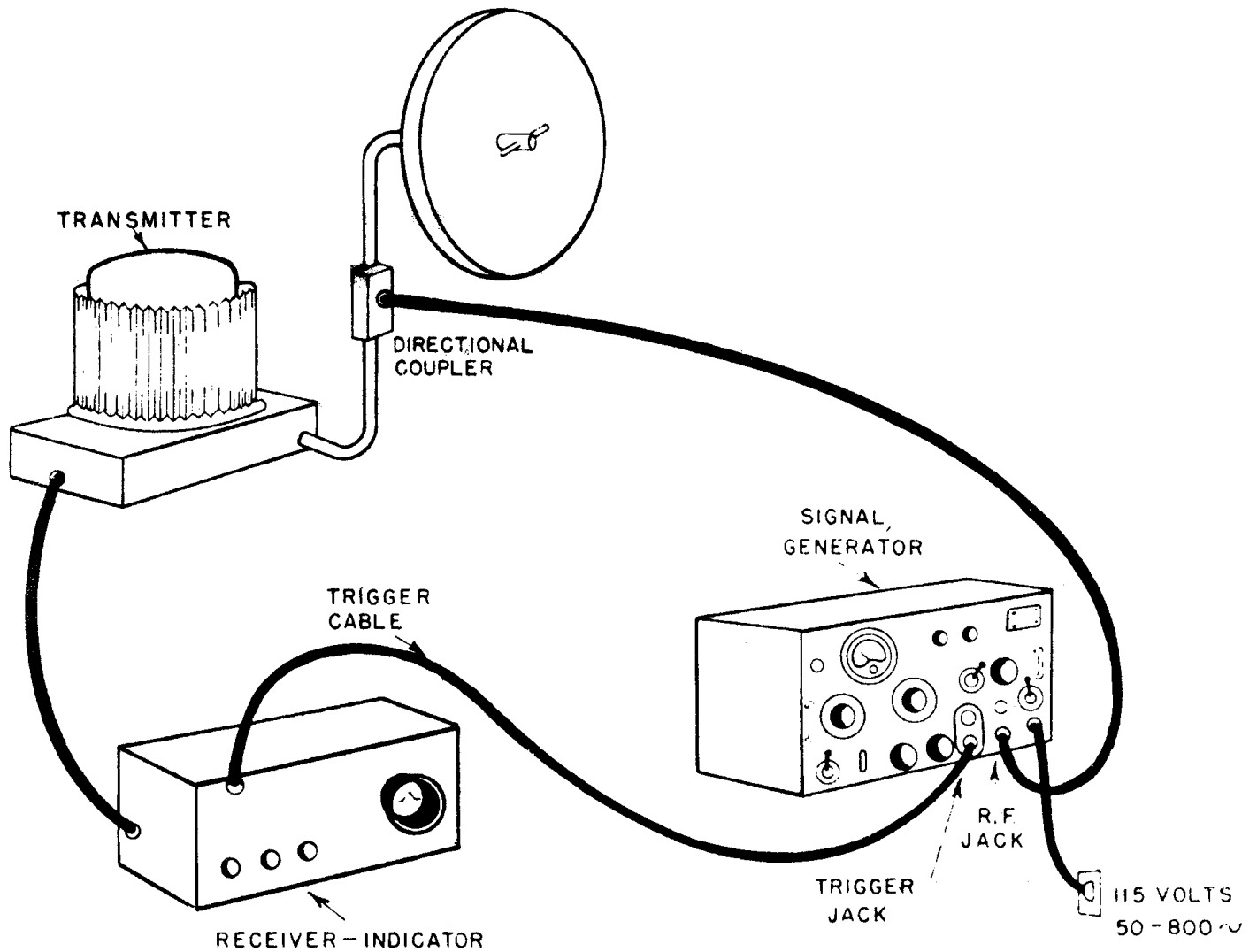

Figure 4. Signal Generator TS-155/UP used with pick-up dipole



TL49859

Figure 5. Signal Generator TS-155/UP used with directional coupler

such a position that the radar antenna, when directed toward the dipole antenna radiates into otherwise free space. The dipole antenna should be rigidly mounted by suitable means using the support bracket with which it is provided.

CAUTION: The test set should never be directly coupled into the antenna line of the radar set. If this is done with the radar transmitter operating, damage to the test set is certain to result. The only case where the test set can be directly connected to the radar set is when the radar set employs a directional coupler.

10. CONNECTION TO DIRECTIONAL COUPLER (fig. 5).

Some radar sets have directional coupler mounted in the r-f plumbing. For such an installation proceed as follows:

a. Connect one end of Antenna Cable CG 70 MPM to the jack on the directional coupler of the radar set. Refer to the technical manual of the particular radar set used for any special instructions about the directional coupler employed.

b. Connect the other end of the antenna cable to the R.F. jack of the signal generator.

PART TWO OPERATING INSTRUCTIONS

NOTE: For information on destroying the equipment to prevent enemy use, refer to the destruction notice at the front of the manual.

SECTION III- PREOPERATIONAL PROCEDURES

11. OPERATING CONTROLS (fig. 6).

The following operating controls are located on the front panel of Signal Generator TS-155/UP

a. *R. F. TUNING Control.* A 270, one hundred division dial for selecting the frequency. The calibrations on the dial are arbitrary.

b. *R. F. ATTENUATOR Control.* An eighty division dial calibrated directly in decibels below 1 milliwatt peak power.

c. *PULSE DELAY Control.* A dual,

continuously variable control. The large knob is for coarse adjustment, the small knob for fine adjustment. Use figure 7 for an approximate setting of this control.

d. *OUTPUT TRIG FREQUENCY Control.* A continuously variable control. The trigger frequency may be set approximately by the use of figure 8 for the TS-155/UP. On the TS-155A/UP, the dial is calibrated directly in cycles per second.

e. *PULSE WIDTH Control.* A continuously variable control. Figure 9 may be used to set the pulse width approximately.

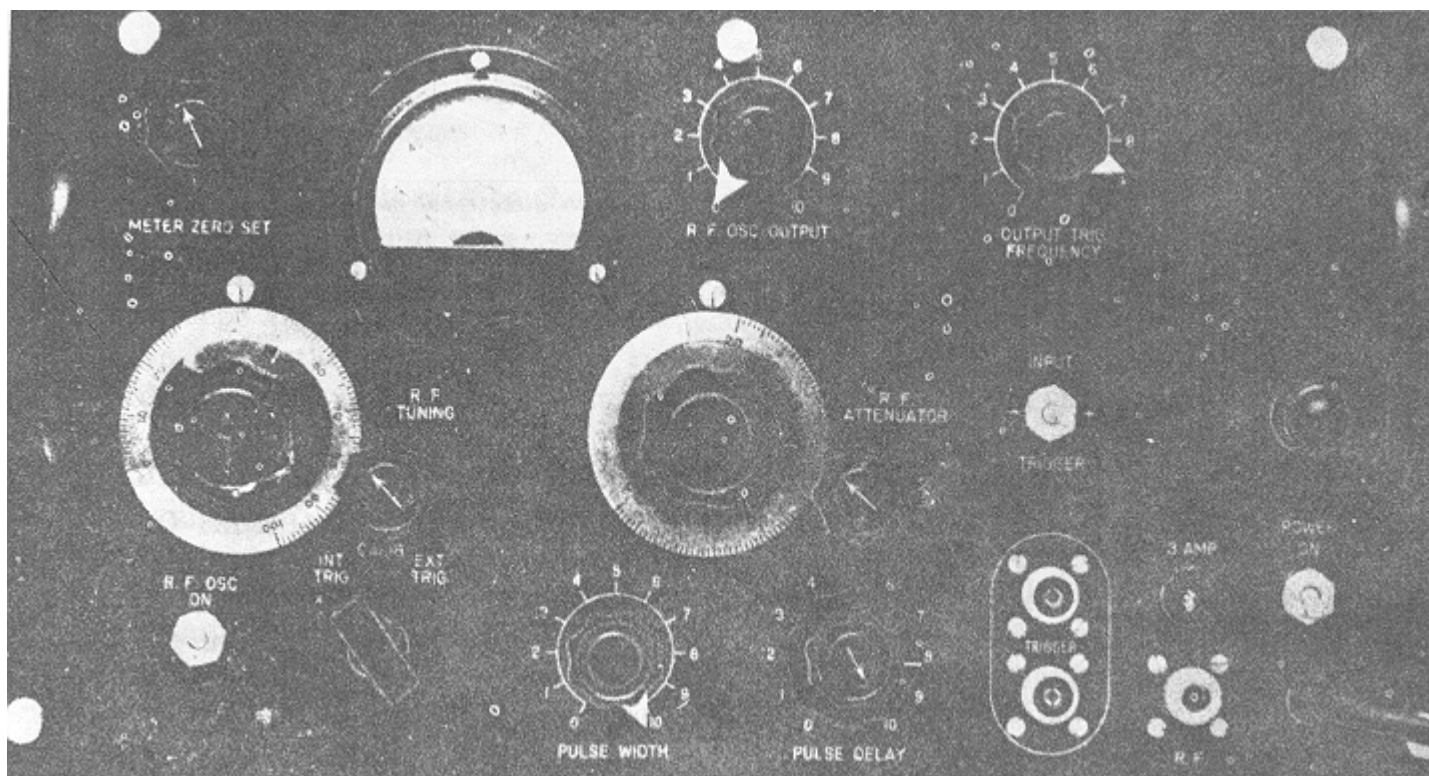
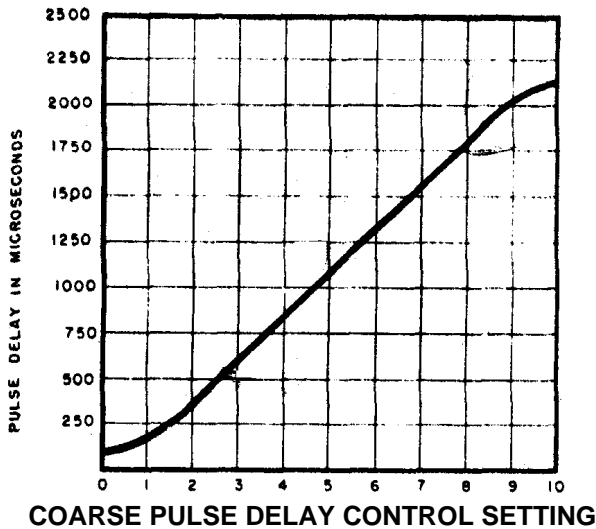

Figure 6. Signal Generator TS-155/UP, operating controls

TL49860



NOTE : PULSE DELAY FOR TYPICAL SIGNAL GENERATOR WITH COARSE AND FINE PULSE DELAY CONTROLS SET AT ZERO IS 3.5 MICRO SECONDS.

TL49861

Figure 7. Coarse PULSE DELAY control settings

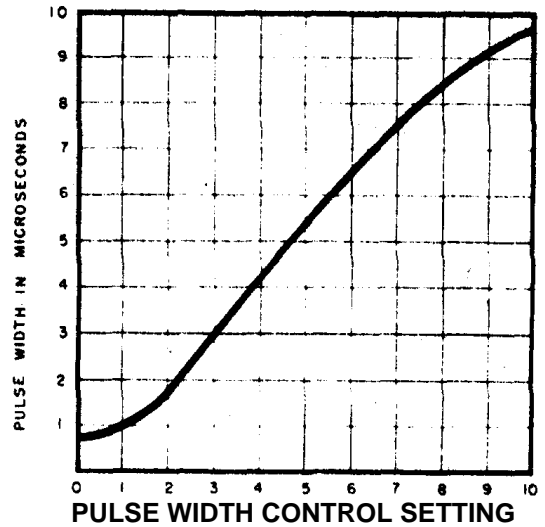

NOTE: THIS CURVE DOES NOT APPLY TO SOME OF THE EARLY DEVELOPMENT MODELS. IT APPLIES ONLY WHEN P4 HAS PART NO 650 503A OR PART NO 650 503C

TL49863

Figure 9. PULSE WIDTH control settings

f. **POWER Switch.** A switch for turning ON or OFF the power supplied to the signal generator.

g. **METER ZERO SET Control.** An adjustment control for setting the zero of the power monitoring meter.

h. **R.F. OSC OUTPUT Control.** Controls the output power delivered by the cavity oscillator.

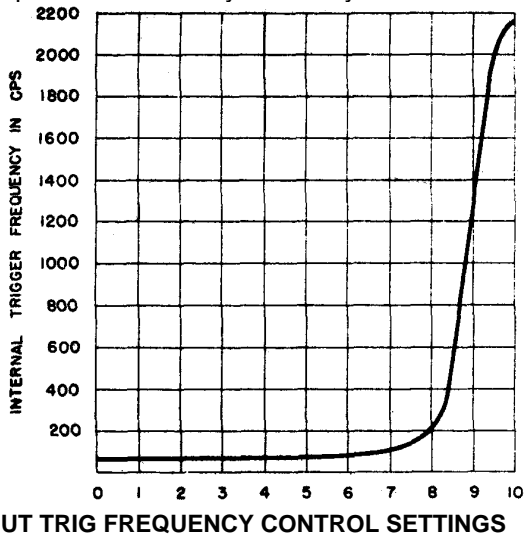

NOTE: THIS CURVE APPLIES TO TS-15/UP ONLY AND NOT TO TS-155A/UP

TL49862

Figure 8. OUTPUT TRIG FREQUENCY control settings

i. **INT TRIG CALIB EXT TRIG Switch.** This selector switch is turned to INT TRIG when the internal trigger supplied by the signal generator is used for synchronization with the radar set. It is turned to CALIB when checking the calibration of the power monitoring meter. It is turned to EXT TRIG when the signal generator is synchronized by means of a trigger taken from the radar set.

j. **R.F. OSC Switch.** For turning ON or OFF the pulse modulating voltage to the cavity oscillator.

k. **INPUT TRIGGER Switch.** Switch for selecting the desired trigger polarity, either positive or negative.

12. CONNECTIONS.

a. The two TRIGGER jacks (Army SO-239) are connected in parallel and are used as follows.

(1) Selector switch in EXT TRIG position: The external synchronizing voltage is fed in through one of the jacks. The other jack may then be used for synchronizing other equipment with the same external synchronizing voltage.

(2) Selector switch in INT TRIG position: The internal synchronizing voltage produced by the signal generator is available at either or both jacks for synchronizing other equipment.

b. The R.F. jack (type N fitting) is used for feeding r-f power into or out of the signal generator.

c. The power cord is secured to the signal generator and lugs into the power source.

13. STARTING PROCEDURE.

a. Connect the power line cable to a source of 50- to 800-cycle, 115-volt power. For 230-volt operation see section I, paragraph 4.

b. Turn the POWER switch to ON, and the R.F. OSC switch to OFF. Wait 3 minutes for the signal generator to warm up.

c. Set the R.F. ATTENUATOR between -35

dbm and -40 dbm (set dial between 35 and 40).

d. Adjust the R.F. OSC OUTPUT control to mid-position.

e. Set the selector switch (left of the PULSE WIDTH control) to CALIB.

f. Turn the METER ZERO SET control until the power monitor meter reads zero.

g. Turn the R.F. OSC switch to ON. The power monitor meter should now indicate that r-f power is being generated. If no output is indicated, increase the R.F. OSC OUTPUT control setting. The amount of power may be varied by the R.F. OSC OUTPUT control.

SECTION IV—OPERATION

14. SYNCHRONIZATION.

Place the signal generator in operation as described in paragraph 13.

a. *External Synchronization.* External synchronization is used when testing a radar set that supplies a trigger.

(1) Connect one of the jacks marked TRIGGER to any suitable trigger. The IFF trigger of the radar set is usually a convenient one for this purpose.

(2) Turn the INPUT TRIGGER polarity switch to + or -, corresponding to the polarity of the trigger used.

(3) Turn the selector switch to EXT TRIG.

b. *Internal Synchronization.* Internal synchronization is used when testing radar sets that can be triggered externally by a positive trigger.

(1) Turn selector switch to INT TRIG. The OUTPUT TRIG FREQUENCY control may be set to any frequency between 120 and 2,000 cycles but should be set to the approximate frequency of the radar set being tested (fig. 8 for TS-155/UP). A positive trigger is available at either or both TRIGGER jacks for synchronization of the radar set.

(2) Connect a trigger cable between one of the TRIGGER jacks and the appropriate jack on the

radar set as specified in the technical manual for the radar set.

15. TESTING OVER-ALL PERFORMANCE OF RADAR SYSTEM

The testing of a radar set consists of measuring the transmitter power output and receiver sensitivity. The data found in these tests can be interpreted so that the absolute conditions of the radar set can be determined, as discussed in subparagraph c below.

a. *Measuring Transmitter Power Output.*

(1) Place the signal generator in operation as described in section III, paragraph 13.

(2) Synchronize either internally or externally as in paragraph 14.

(3) Turn R.F. OSC switch to OFF.

(4) Turn the METER ZERO SET knob to adjust the power monitor meter to zero.

(5) Connect one end of the antenna cable to the R.F. jack. The other end of the antenna cable should be connected to Antenna Assembly AS-23/AP, installed as in section II, paragraph 9, or a directional coupler installed as in section II, paragraph 10.

(6) Turn the radar set on.

(7) Turn the R.F. ATTENUATOR knob clockwise to the red reference mark. When the R.F. ATTENUATOR dial is set to the red mark, the power monitor meter reads directly the number of milliwatts average power input at the R.F. jack.

(8) If using a dipole, follow (a) and (b) below. If using a directional coupler, omit (a) and (b) and proceed as in subparagraph (9) below.

(a) Check installation of Antenna Assembly AS-34/AP, to see that it is positioned in the plane of polarization of the radar antenna, and that the reflector antenna is facing away from the radar antenna as shown in figure 4.

(b) Adjust the antenna elevation and azimuth of the radar set for maximum reading of power monitor meter on the signal generator

(9) Very slowly turn the R.F. TUNING knob from one end of its range to the other while watching the power monitor meter. As the radar transmitter frequency is reached, a sharp dip will be observed.

(10) Read and record the R.F. TUNING dial scale position at the minimum power monitor meter scale reading

NOTE: The R. F. TUNING dial has a graduate scale which can be calibrated with an external wavelength to give a rough measurement of radar frequency or wavelength within an accuracy of about 6 mc or 0.02 cm.

(11) Turn the R.F. TUNING dial to 0 or 100, whichever is farther away from the reading found in (10) above. This operation detunes the signal generator cavity from the radar frequency, so that the cavity will not absorb part of the power.

(12) Note the maximum reading on the power monitor meter. This meter reading is the radar transmitter average power output in milliwatts at the signal generator R.F. jack. If the position of the pick-up dipole is kept constant as described in section II, paragraph 9, or if the same directional coupler is used in all tests., this meter reading will be roughly proportional to the radar transmitter power output. The power monitor of the signal generator serves as an r-f

wattmeter and utilizes only a small fraction of the r-f power of the transmitter in measuring its power output.

b. Measuring Receiver Sensitivity.

Two procedures of measuring receiver sensitivity are given. Case 1 is to be used when the radar receiver has been previously aligned with the transmitter. Case 2 is to be used when the receiver is not aligned with the transmitter and there are no simple tune-up procedures available, such as local signals or an echo box with tuning meter. For both cases the procedure is the same except for step (6) where alternative instructions are given.

(1) Follow the procedure of subparagraph a above.

(2) Turn the selector switch to CALIB and turn the R.F. ATTENUATOR dial to approximately -40 dbm.

(3) Turn the R.F. OSC switch to ON and turn the R.F OSC OUTPUT control until the monitor meter reads 200. Set the PULSE DELAY and PULSE WIDTH to the center of their scales.

(4) Set radar range sweep so that a signal at a range of 12 miles (about 22,000 yards) could be seen. Set the selector switch to either INT TRIG or EXT TRIG as described in section III, paragraph 14.

(5) Turn the R F TUNING dial counterclockwise three divisions from the reading found in subparagraph a(10) above.

(6) Align the receiver and signal generator to the same frequency by the method described in case 1 or case 2, whichever applies

CASE 1

When the radar receiver has been previously aligned with the transmitter and the radar set is known to be in normal operating condition, proceed as follows:

(a) Tuning Signal Generator to Frequency of Radar Receiver.

1. Adjust the R.F. TUNING dial plus or minus two divisions about the value obtained in

subparagraph b(5) above, until maximum signal is found on the radar indicator at approximately 12-miles range. If no signal is visible, set the ATTENUATOR control to the red mark and repeat the process.

2. Identify the signal by turning the PULSE DELAY control back and forth about mid-position. The signal from the signal generator will move into synchronization with the PULSE DELAY control. Set the PULSE DELAY control so that the signal from the signal generator does not interfere with any other signals.

3. If necessary, turn the R.F. ATTENUATOR dial counterclockwise to bring the signal below saturation, and then complete the tuning operation, adjusting the PULSE WIDTH control to give a signal width that appears as wide a normal echo.

CASE 2

When the radar receiver is not aligned with the transmitter, and no local signal or echo is available, proceed as follows:

(b) Tuning Radar Receiver to Frequency of Signal Generator.

1. Set the R F. ATTENUATOR dial to . Calibration reference mark (red line) to provide a large signal.

2. Tune the radar receiver local oscillator until a signal appears on the screen at approximately 12 mile range.

3. Identify the signal by tuning the PULSE DELAY control back and forth about mid-position. The signal from the signal generator will move in synchronization with the PULSE DELAY control. Set the PULSE DELAY control so that the signal from the signal generator does not interfere with any other signals.

4. Tune the T/R box and the mixer for a maximum signal. If necessary, turn the R.F. ATTENUATOR dial counterclockwise to bring the signal below saturation and then complete the tuning operation.

(7) Set the R.F. ATTENUATOR dial to approximately 40 dbm.

(8) Turn the R.F. OSC switch to OFF.

(9) Turn the selector switch to CALIB.

(10) Readjust the METER ZERO SET control for zero reading of the meter.

(11) Turn the R.F. OSC switch to ON and turn the R.F. OSC OUTPUT control until the power monitor meter reads 200. This standardizes the signal generator for measuring receiver sensitivity.

(12) Turn the selector switch to INT TRIG or EXT TRIG corresponding to the type of synchronization used.

(13) If an A-scope is used, turn the R.F. ATTENUATOR dial counterclockwise until the signal just disappears in the grass. If a PPI or B-scope is used, reduce the signal by means of the R.F ATTENUATOR until it just disappears. The accuracy of this test is improved by moving the signal in range by means of the PULSE DELAY control while attenuating. Record the R.F. ATTENUATOR dial reading. This reading is a relative measure of the sensitivity of the radar receiver (expressed in decibels relative to 1 milliwatt), peak power measured at the R.F. jack of the signal generator. To obtain the absolute sensitivity, the cable and the spare attenuation or the attenuation constant of the directional coupler must be known. The greater the R.F. ATTENUATOR. dial reading, the greater the receiver sensitivity.

NOTE: If the procedure of Case 2 in subparagraph b(6) above is used, the radar set may not be precisely tuned to maximum performance. It may be necessary to retune the radar set slightly, using actual signals or an echo box provided with a tuning meter, to obtain peak performance.

c. Interpretation of Tests

(1) Using Directional Coupler. When the radar set being tested has a directional coupler in the r-f plumbing, it is comparatively easy to convert relative power to absolute power at the radar set. The data and sample calculations following will serve as a guide in determining the absolute power.

(a) Convert average transmitter power at the signal generator to peak power at the radar transmitter.

1. When the radar set is operating satisfactorily, the average radar transmitter

power output will be found as in subparagraph a above using a directional coupler.

2. Record the meter reading as observed in paragraph 15a (12).

3. Note the attenuation constant of the directional coupler as stamped on the coupler.

4. Determine the peak power at the radar transmitter, using the following example as an illustration: The average power of the radar set must first be determined. The reading of the monitor meter on the signal generator is found to be 75 milliwatts. The average attenuation of r-f Cord CG-70/MPM is 3 db. This cable connects the signal generator to the directional coupler of the radar set. The attenuation constant of the directional coupler is found to be 35 db (marked on the coupler).

a. Convert the 75 mw to dbm, using graph I, obtaining as a result 18.8 dbm.

b. Add the cable and directional coupler attenuation to the value in dbm found above. This gives the average power in dbm at the radar transmitter, in the main guide at the directional coupler. The value found is: 18.8 dbm + 35 db or 56.8 dbm.

c. The figure just obtained should be compared with an established figure based on the average power rating of the radar transmitter. If it found that the radar transmitter is down by 2 or 3 db or more, an investigation should be made to determine the cause.

d. The peak power in dbm at the radar transmitter may be determined, if desired, by use of graph II.

GRAPH I

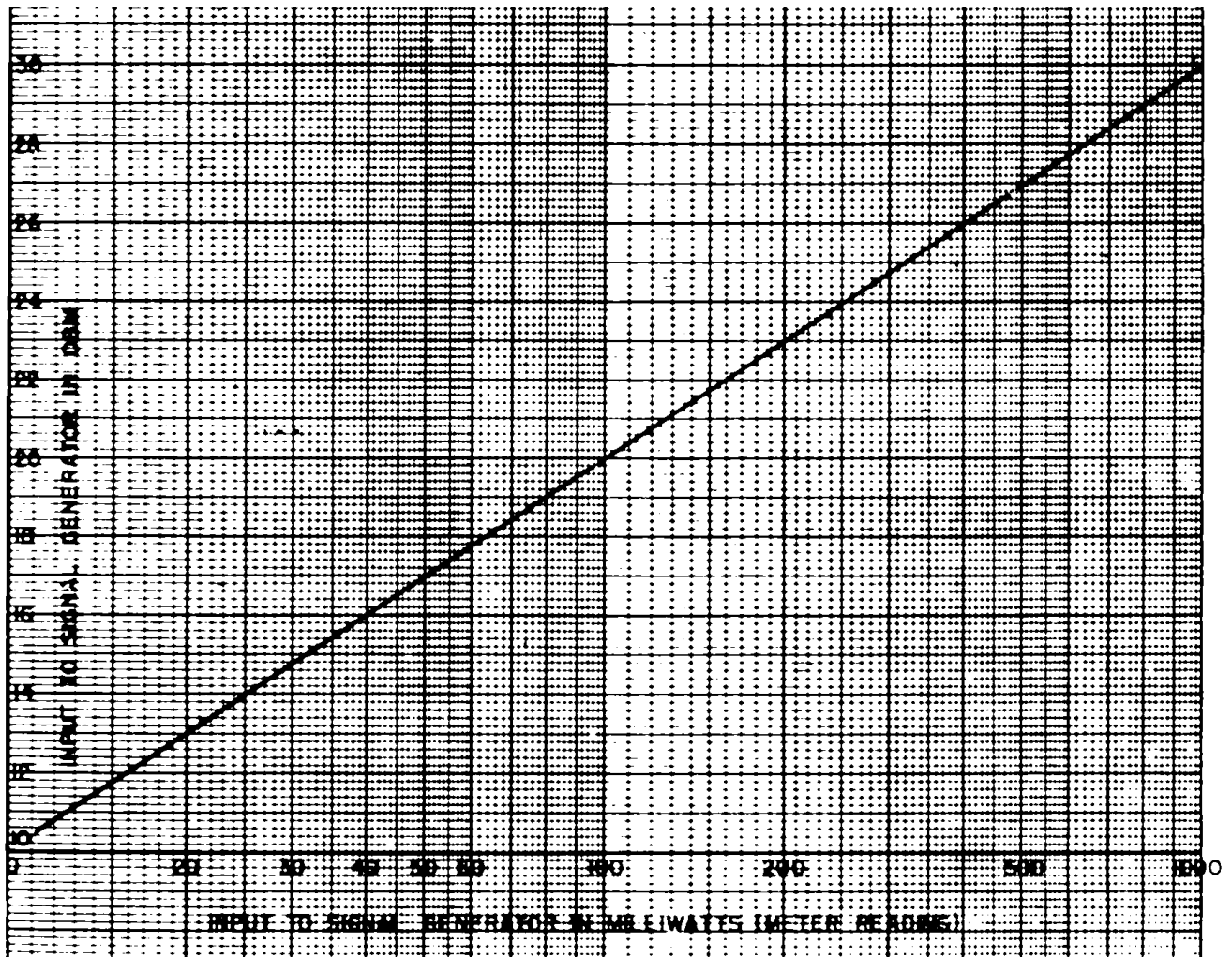

GRAPH I CONVERSION OF INPUT TO SIGNAL GENERATOR IN MILLIWATTS TO DBM

GRAPH II

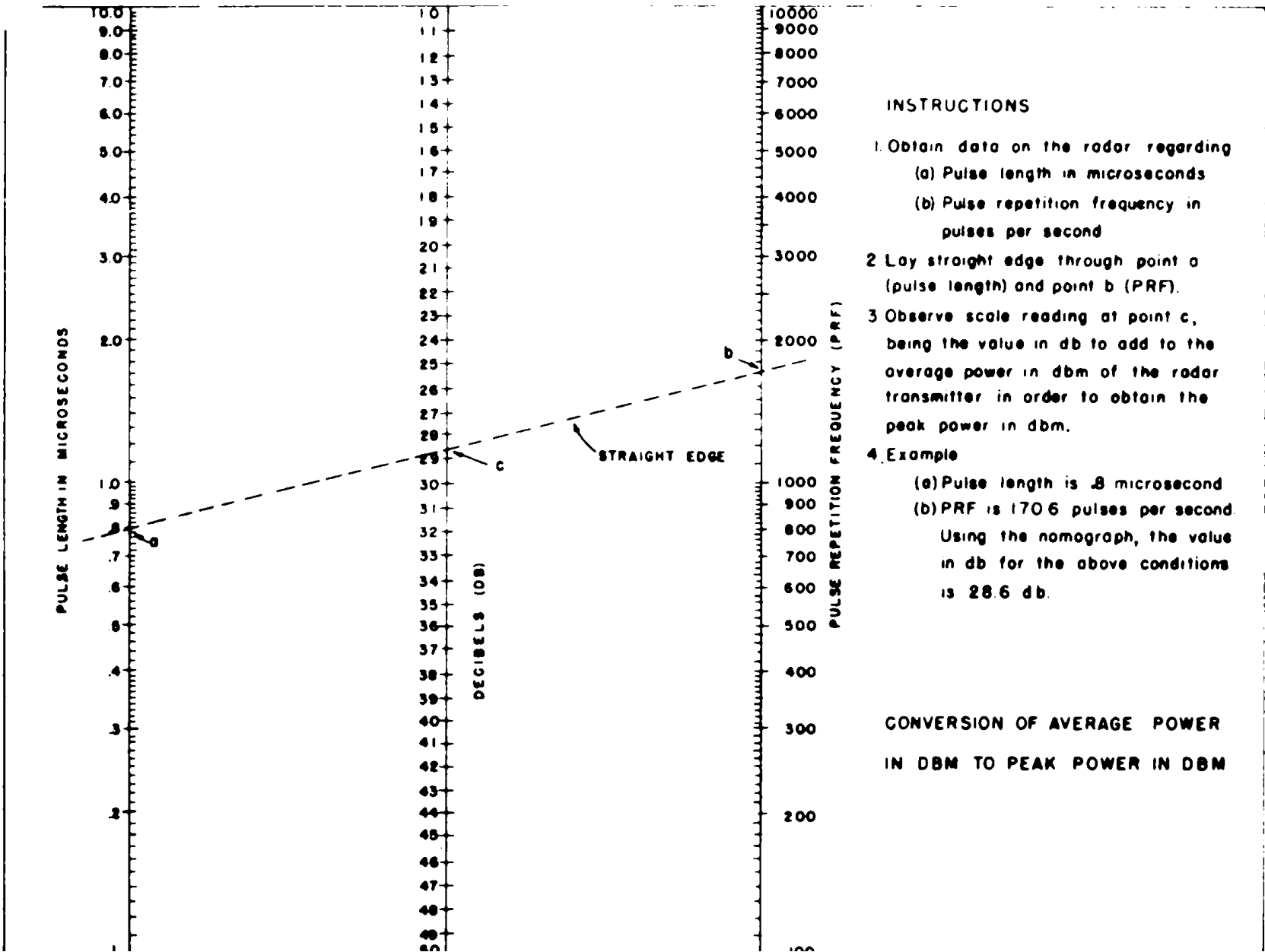

(b) Convert relative sensitivity as measured at the test set to actual receiver sensitivity.

1. When a radar set is operating satisfactorily, the receiver sensitivity will be found as in subparagraph b(6), case 1.

2. Record the reading of the R.F. ATTENUATOR dial observed in subparagraph b (13). This reading is the peak power output of the signal generator in db below 1 milliwatt.

3. Note the attenuation constant of the directional coupler as stamped on the coupler.

4. Convert the peak power of the signal generator to minimum discernible signal in the r-f line at the directional coupler by the following equation: $s = -(A_r + C + D)$, where s is the receiver sensitivity (minimum discernible signal in the r-f line at the directional coupler in dbm), A_r is the attenuator dial reading in db below 1 mw, C is the attenuation of the r-f cable in db, and D is the attenuation constant of the directional coupler in db.

5. Sample calculation: The reading of the R.F. ATTENUATOR dial on the signal generator is found to be -60 dbm as determined in subparagraph b(13). The average attenuation of Cord CG-70/MPM is 3 db. The attenuation constant of the directional coupler is 35 db. Using these values the sensitivity of the receiver is: $s = -(A_r + C + D)$ or -60 -3 -35 or -98 dbm.

(2) *Using Space Coupling.*

(a) When the radar set without a directional coupler is being tested, a dipole antenna is used to pick up the r-f energy, with the installation as in paragraph 9. Since the dipole-antenna -gain, space-loss, and radar-antenna-gain measurements are rather difficult to make and require special equipment not supplied with this signal generator, absolute power measurements cannot be made (subpar. c(1)). However, the measurements of transmitter power output in subparagraph a and receiver sensitivity in subparagraph b initially obtained when the radar set was normal (optimum operating condition) can be

combined with similar data obtained during the periodic check; as a result an overall performance figure expressed in db can be obtained. This may be converted to percent of total effective range by use of table II.

NOTE: It is essential that the measuring technique used in the initial measurement and in subsequent periodic checks be identical. It is particularly important that the dipole antenna be installed in the same test position.

(b) The procedure is to substitute the normal performance values obtained initially and the periodic check values into the equations given below. In the example worked out below, P1 and S1 are the values of normal power output and receiver sensitivity, while P2 and S2 are the values, obtained in a hypothetical periodic check.

(c) Example:

1. If P1=150 milliwatts (150 microamperes on power monitor meter) and P2=48 milliwatts, then $P2/P1=48/150=0.32$. Referring to table I this corresponds to -5 db. Hence the power output of the radar transmitter is down 5 db.

2. If S1=69 db (69 divisions on R.F. ATTENUATOR dial) and S2=64 db, then $S1-S2=69-64=5$ db. Hence the radar receiver sensitivity is down 5 db.

3. To determine the resultant effective range of the radar set, add the db values of both the transmitter and receiver:

Transmitter	-5 db
Receiver	-5 db
Over-all	-10 db

4. Referring to table II. it is evident that a system which is down in performance by 10 db will have a maximum range which is roughly 56 percent of the normal (optimum) range.

TABLE I

POWER RATIO VS DB
RELATIVE TO
STANDARD OUTPUT

P ₁ =reference power output measured when radar system is normal.					
P ₂ =power output measured at time of periodic check.					
Power in db relative to P ₁ =10 x log ₁₀ P ₂ /P ₁					
Db P₂/P₁		Db P₂/P₁		Db P₂/P₁	
-10	0.10	-3	0.50	+4	2.5
-9	0.13	-2	0.63	+5	3.2
-8	0.16	-1	0.79	+6	4.0
-7	0.20	0	1.0	+7	5.0
-6	0.25	+1	1.3	+8	6.3
-5	0.32	+2	1.6	+9	7.9
-4	0.40	+3	2.0	+10	10.0

(3) Explanation of Table II.

(a) When the radar transmitter power output is standard, the radar set range is called normal or 100 percent. If the power output and or the receiver sensitivity are below standard, the range obtainable with the radar set decreases to the percent of normal range shown in table II.

(b) This table is based on the inverse fourth power law which applies to aircraft radar and ground or ship radar when used in searching for aircraft at high angles. The change in radar range as a function of radar performance differs somewhat from this table

TABLE II

RADAR RANGE VS
RADAR PERFORMANCE

Performance down in db	Percent of total effective range
0	100%
-5	92%
-3	84%
-5	75%
-10	56%
-15	42%
-20	32%
-25	24%
-30	18%
-35	13%
-40	10%
-45	7.5%
-50	6.0%

for low-angle searching, particularly over water.

(4) Explanation of Table III. This table shows the peak power delivered to a matched load of 50 ohms at the R.F. jack when the signal generator is operated as described in the text. The R.F. ATTENUATOR dial calibrations between 20 and 100 indicate directly db below a reference level of 1 milliwatt. For example, a dial reading of 20 means that the output power is 20 db less than the reference level of 1 milliwatt. This may also be expressed as -20 dbm, and this, as the table indicates, corresponds to an output power of 10 x 10⁻⁶ watts, or 10 microwatts, or 0.01 milliwatts.

TABLE III

ATTENUATOR CALIBRATION DATA

Attenuator dial reading	Peak power output in watts	Attenuator dial reading	Peak power output in watts
20.0	10.00×10^{-6}	60.0	10.00×10^{-10}
21.0	7.95×10^{-6}	61.0	7.95×10^{-10}
22.0	6.31×10^{-6}	62.0	6.31×10^{-10}
23.0	5.01×10^{-6}	63.0	5.01×10^{-10}
24.0	3.98×10^{-6}	64.0	3.98×10^{-10}
25.0	3.16×10^{-6}	65.0	3.16×10^{-10}
26.0	2.51×10^{-6}	66.0	2.51×10^{-10}
27.0	2.00×10^{-6}	67.0	2.00×10^{-10}
28.0	1.58×10^{-6}	68.0	1.58×10^{-10}
29.0	1.26×10^{-6}	69.0	1.26×10^{-10}
30.0	10.00×10^{-7}	70.0	10.00×10^{-11}
31.0	7.95×10^{-7}	71.0	7.95×10^{-11}
32.0	6.31×10^{-7}	72.0	6.31×10^{-11}
33.0	5.01×10^{-7}	73.0	5.01×10^{-11}
34.0	3.98×10^{-7}	74.0	3.98×10^{-11}
35.0	3.16×10^{-7}	75.0	3.16×10^{-11}
36.0	2.51×10^{-7}	76.0	2.51×10^{-11}
37.0	2.00×10^{-7}	77.0	2.00×10^{-11}
38.0	1.58×10^{-7}	78.0	1.58×10^{-11}
39.0	1.26×10^{-7}	79.0	1.26×10^{-11}
40.0	10.00×10^{-8}	80.0	10.00×10^{-12}
41.0	7.95×10^{-8}	81.0	7.95×10^{-12}
42.0	6.31×10^{-8}	82.0	6.31×10^{-12}
43.0	5.01×10^{-8}	83.0	5.01×10^{-12}
44.0	3.98×10^{-8}	84.0	3.98×10^{-12}
45.0	3.16×10^{-8}	85.0	3.16×10^{-12}
46.0	2.51×10^{-8}	86.0	2.51×10^{-12}
47.0	2.00×10^{-8}	87.0	2.00×10^{-12}
48.0	1.58×10^{-8}	88.0	1.58×10^{-12}
49.0	1.26×10^{-8}	89.0	1.26×10^{-12}
50.0	10.00×10^{-9}	90.0	10.00×10^{-13}
51.0	7.95×10^{-9}	91.0	7.95×10^{-13}
52.0	6.31×10^{-9}	92.0	6.31×10^{-13}
53.0	5.01×10^{-9}	93.0	5.01×10^{-13}
54.0	3.98×10^{-9}	94.0	3.98×10^{-13}
55.0	3.16×10^{-9}	95.0	3.16×10^{-13}
56.0	2.51×10^{-9}	96.0	2.51×10^{-13}
57.0	2.00×10^{-9}	97.0	2.00×10^{-13}
58.0	1.58×10^{-9}	98.0	1.58×10^{-13}
59.0	1.26×10^{-9}	99.0	1.26×10^{-13}
		100.0	10.00×10^{-14}

PART THREE

PREVENTIVE MAINTENANCE

SECTION V - PREVENTIVE MAINTENANCE TECHNIQUES

16. MEANING OF PREVENTIVE MAINTENANCE.

Preventive maintenance is a series of operations performed at regular intervals on equipment, when turned off, to eliminate major breakdowns and unwanted interruptions in service, and to keep the equipment operating at top efficiency. To understand what is meant by preventive maintenance, it is necessary to distinguish between preventive maintenance, trouble shooting, and repair. The prime function of preventive maintenance is to prevent break-downs and, therefore, the need for repair. On the other hand, the prime function of trouble shooting and repair is to locate and correct existing defects. The importance of preventive maintenance cannot be overemphasized. The satisfactory operation of a radar set depends upon its readiness and operating efficiency when it is needed. In a similar manner, the test equipment by which this condition of readiness is realized must be kept in excellent operating condition at all time.

- I inspect
- T Tighten.
- C Clean.
- A Adjust
- L Lubricate

The first operation establishes the need for the other four. The selection of operations is based on a general knowledge of field need. For example, the dust encountered on dirt roads during cross country travel filters into the equipment no matter how much care is taken to prevent it. Rapid changes in weather (much as heavy rain followed by blistering heat), live dampness, snow, and ice tend to cause corrosion of exposed surfaces and parts. Without frequent inspections and the necessary performance of tightening, cleaning, and lubricating operations, equipment becomes undependable and subject to breakdown when it is most needed.

17. DESCRIPTION OF PREVENTIVE MAINTENANCE TECHNIQUES

a. *General.* Most of the electrical parts used in Signal Generator TS-155/UP require routine preventive maintenance. Those requiring maintenance differ in the amount and kind required. Because hit-or-miss techniques cannot be applied, definite and specific Instructions are needed. This section of the manual contains these specific instructions and serves as a guide for personnel assigned to perform the five basic maintenance operations, namely: Inspect, Tighten, Clean, Adjust, and Lubricate. Throughout this manual the lettering system for the five operations will be as follows:

b. *Inspect.* Inspection is the most important operation in the preventive maintenance program. A careless observer will overlook the evidences of minor trouble. Although these defects may not interfere with the performance of the equipment, valuable time and effort can be saved if they are corrected before they lead to major break-down. Make every effort to become thoroughly familiar with the indications of normal functioning, in order to be able to recognize the signs of a defective. Inspection consists of carefully observing all parts of the equipment, noticing their color, placement, state of cleanliness, etc. Inspect for the following conditions:

(1) Overheating, indicated by discoloration, blistering or bulging of the parts of the container; leakage of insulating compounds; and oxidation of metal contact surfaces.

(2) Improper placement, by observing that all leads and cabling are in their original positions

(3) Lack of cleanliness, by carefully examining all recesses in the units for accumulation of dust, especially between connecting terminals. Parts, connections, and joints should be free of dust, corrosion, and other foreign matter. In tropical and high-humidity locations, look for fungus growth and mildew.

(4) Looseness, by testing any connection or mounting which appears to be loose.

c. Tighten, clean and Adjust. These operations are self-explanatory. Specific procedures to be followed in performing them are given wherever necessary throughout part three.

CAUTION: Screws, bolts, and nuts should not be tightened carelessly. Fittings tightened beyond the pressure for which they are designed will be damaged or broken. Whenever a loose connection is tightened, it should be moistureproofed and fungiproofed again by applying the varnish with a small brush See section VIII for details of moisture-proofing and fungiproofing.

d. Lubricate. Lubrication refers to the application of grease or oil to the bearings of motors or other rotating shafts It may also mean the application of a light oil to door hinges or other sliding surfaces on the equipment.

SECTION VI - ITEMIZED PREVENTIVE MAINTENANCE

18. INTRODUCTION.

In this section the preventive maintenance work to be performed on the test set at specified time intervals is broken down into units of work called items. The specified intervals at which each item is to be performed are scheduled in paragraph 26.

19. COMMON MATERIALS NEEDED.

The following materials will be needed in performing preventive maintenance:

Common hand tools
Clean cloth.
#0000 sandpaper.
Crocus cloth
Solvent, Dry-cleaning, Federal Specification P-S-661a.

NOTE: The use of leaded gasoline for cleaning purpose is prohibited by AR 850-20. Solvent, Dry-cleaning, Federal Specification P-S-661a, is available as a cleaning fluid through established channels. Oil, Fuel, Diesel U. S. Army Specification 2-102B, may be used for cleaning purposes when dry-cleaning

solvent is not at hand. Since unleaded gasoline is available in limited quantities and only in certain locations, it should be used for cleaning purposes only when no other agent is suitable. Carbon tetrachloride, or fire-extinguishing liquid (carbon tetrachloride base), will be used, if necessary, only on contact parts of electronic equipment.

20. ITEM 1, EXTERIOR OF SIGNAL GENERATOR TS-155/UP.

a. Preliminary Steps. Remove the signal generator from the transit case.

b. Inspect. Inspect the exterior of the signal generator for dust, dirt and corrosion. Check the power cable for rubber deterioration, excess wear, cuts, and kinks. Replace the cable if necessary. Give special attention to the R.F. and TRIGGER jacks If the meter glass is cracked, replace the glass or repair it temporarily with friction tape. Be sure the 3-AMP fuse is inserted properly. Check all control knobs for looseness.

c. Tighten. Tighten any loose control knobs, being sure not to disturb their calibration.

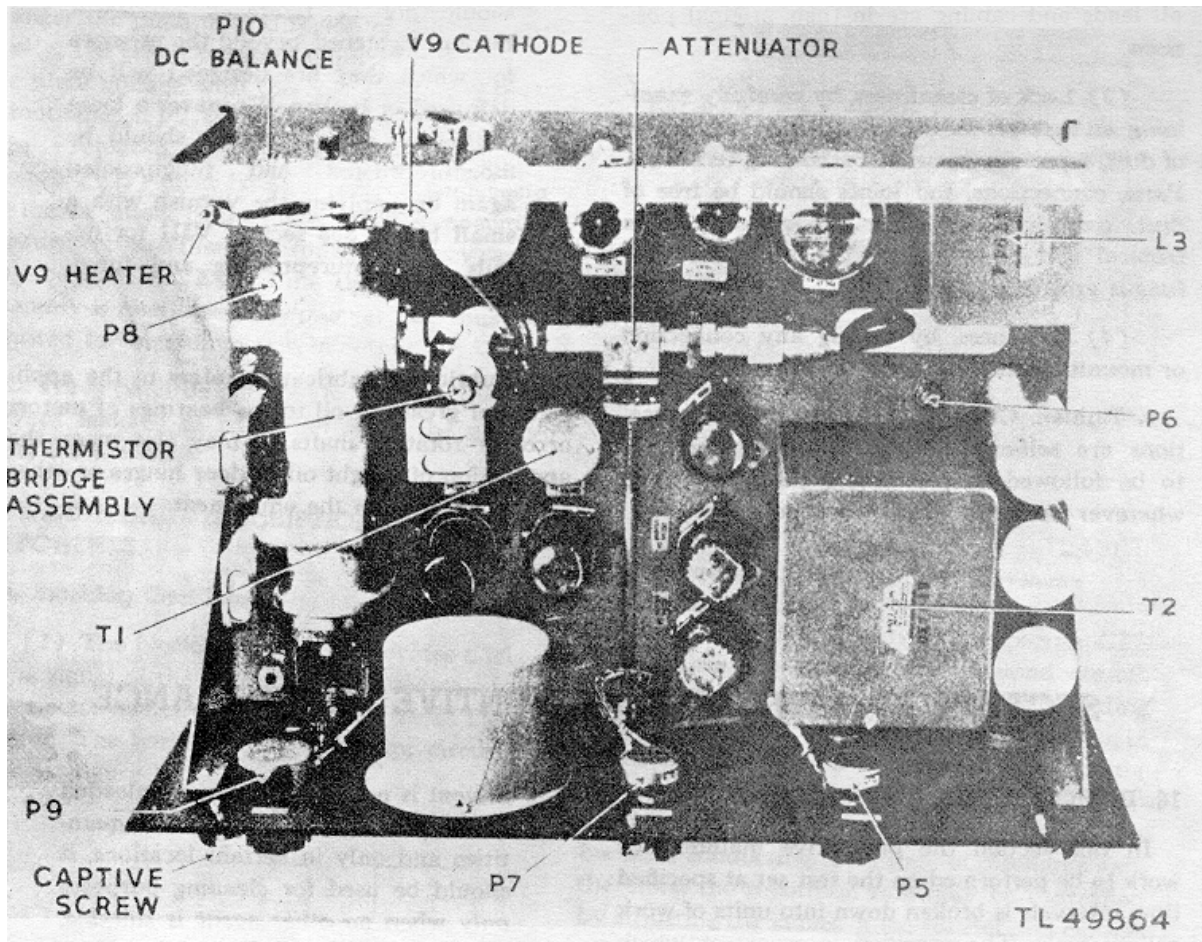

Figure 10. Top of chassis

d. *Clean.* Clean R F. jack, TRIGGER jacks., and power plug with a cloth, or if necessary, with crocus cloth. Remove grease and oil from the power cable with a soft rag dampened with dry cleaning solvent. Clean the meter glass. Remove grease and dirt from the exterior of the signal generator with a cloth. Moisten the cloth with dry-cleaning solvent if necessary. Touch up the exterior of the signal generator with paint if necessary.

21. ITEM 2, TOP OF CHASSIS (fig. 10).

a. *Preliminary Steps.*

(1) Remove the chassis from the cover by loosening the five captive screws on the front panel (ten captive screws on TS-155A/UP).

(2) Discharge the high-voltage capacitors before performing any of the following steps.

b. *Inspect.* The entire top of the chassis for cleanliness. Check all nuts, screws, and bolts for tightness. Check for firmness of the tubes in their sockets. Do not partially withdraw them and then move them from side to side in their sockets. Inspect tubes by pressing them firmly into their sockets and test them in that position. Check the transformer and choke for signs of overheating. The high-voltage capacitors should be checked for bulges. Check all electrical connections. Inspect the attenuator and tuning gears for wear and excess lubrication.

c. *Tighten.* All loose mounting nuts and bolts. The r-f output cable connector must be tight. Be sure all tube clamps are fastened properly.

d. *Clean.* Clean the entire top of the chassis. Remove the dust and dirt on the tubes with a clean dry cloth. Clean the exterior of the cavity and attenuator. Use care in cleaning the thermistor bridge assembly.

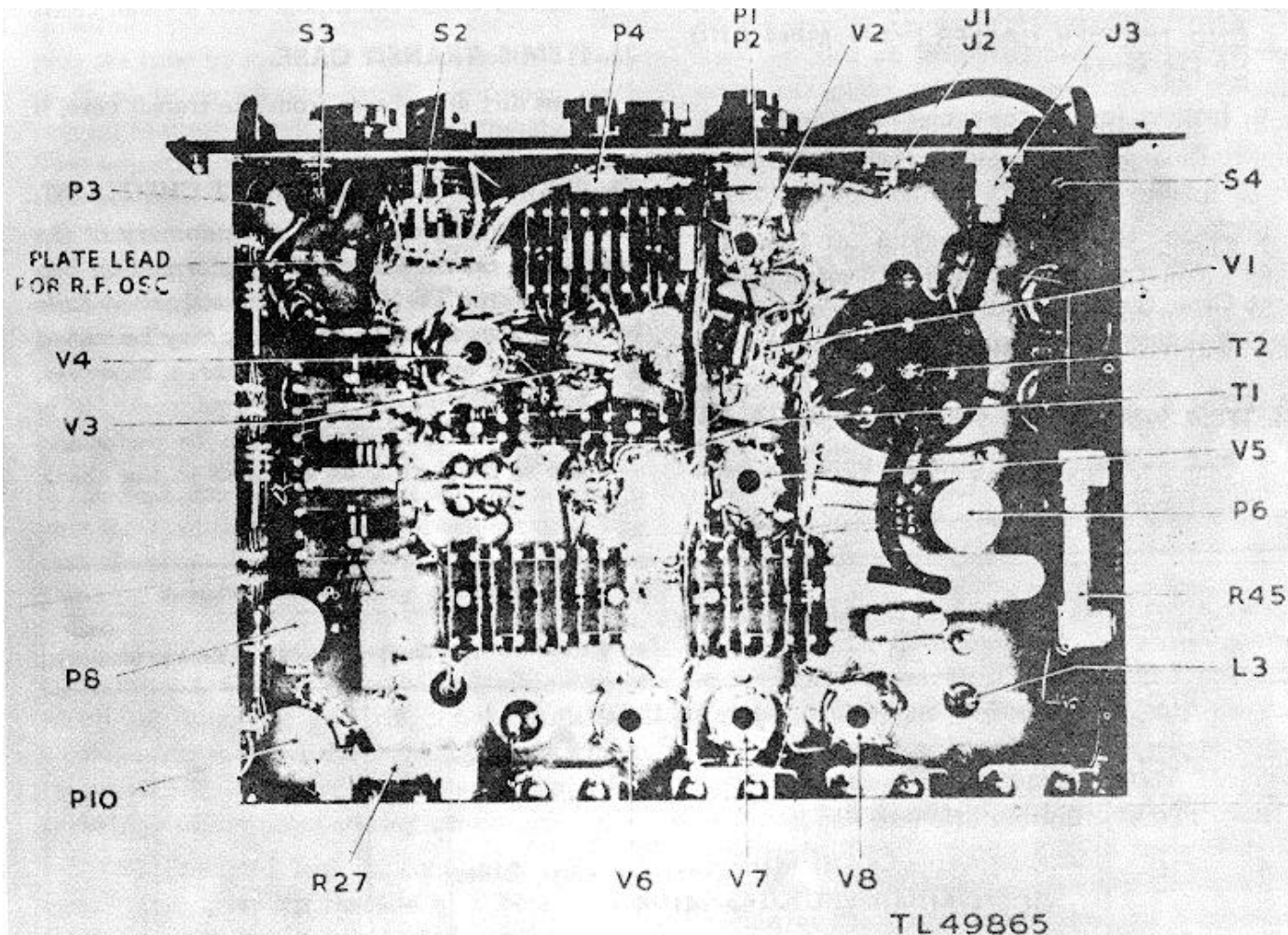

Figure 11. Bottom of chassis

Clean the r-f tuning and r-f attenuator gears, if necessary. The cavity should not be disassembled for routine preventive maintenance. Repair of the cavity and instructions for disassembly are given in part five.

e. *Lubricate.* Apply a few drops of Oil, Engine, U. S. Army Spec. No. 2-104B to the r-f attenuator and r-f tuning gears after they have been thoroughly cleaned.

22. ITEM 3, BOTTOM OF CHASSIS (fig. 11).

a. Preliminary Steps.

(1) Remove the chassis from the cover by loosening the captive screws on the front panel.

(2) Discharge the high-voltage capacitors before performing any of the following steps.

b. *Inspect.* Inspect the bottom of the chassis and all parts for cleanliness. Inspect all mounting bolts for tightness. The tube socket connections should be inspected for tightness and well-soldered connections.

All electrical connections must be tight. Soldered connections must be mechanically and electrically sound. Inspect the transformer bushings for cracks and dirt. Inspect all resistor and capacitor boards for dirt and defective parts. Look for burned-out resistors. Inspect the contacts of switch S2. Check the two ferrule resistors for discoloration or other signs of possible trouble. Replace any resistors showing signs of possible failure.

c. *Tighten.* Tighten all mounting screws and screw-type terminals.

d. *Clean.* Clean the entire bottom of the chassis. Pay particular attention to the transformer bushings. Clean the contacts of switch S2 with crocus cloth or fine sandpaper. Be sure to clean the switch carefully after surfacing the contacts.

e. *Adjust.* The position of the wiring and r-f output cable. Carefully adjust the contacts of switch S2 if they are out of line.

23. ITEM 4. ANTENNA CABLE CG-70 MPM AND TRIGGER CABLES CG-71 MPM AND CX-145 MPM.

a. Inspect. Inspect the cables for deterioration, excess wear, cuts, and kinks. Inspect the plugs on each end.

b. Clean. Remove grease and oil from the cables with a cloth dampened with cleaning solvent. Clean the plugs with a dry cloth or, if necessary, with fine sandpaper or crocus cloth.

24. ITEM 5. ANTENNA ASSEMBLY AS-23/AP.

a. Inspect. Inspect the pick-up dipole for bent or damaged parts.

b. Clean. Clean the dipole with a clean cloth

25. ITEM 6. TRANSIT CASE

Clean dirt and grease from the transit case, if necessary.

26. PREVENTIVE MAINTENANCE CHECK LIST.

The following check list is a summary of the preventive maintenance to be performed on Signal Generator TS-155/UP. The suggested time intervals shown on the check list may be varied at any time by the person in charge. However, for best performance of the equipment, it is recommended that the operations be performed at least as frequently as specified in the check list.

Item No.	Operations	Description of Item	When performed			
			Daily	Weekly	Monthly	Semi-annually
1	ITC	Exterior of Signal Generator TS-155/UP	X			
2	ITCL	Top of chassis			X	
3	ITCA	Bottom of chassis			X	
4	IC	Antenna Cable CG-70 MPM and Antenna Cables GG-71 MPM and CX-145 MPM		X		
5	IC	Antenna Assembly AS-23/AP		X		
6	C	Transit case		X		

I
Inspect

TA
Tighten

C
Adjust

L
Clean

Lubricate

SECTION VII – LUBRICATION

27. LUBRICATION INFORMATION.

The only lubrication required is covered in section VI, paragraph 21e.

SECTION VIII – MOISTUREPROOFING AND FUNGIPROOFING

28. GENERAL.

The operation of Signal Corps equipment requires special attention in tropical areas where temperature and relative humidity are extremely high. The following items represent problems which may be encountered during operation.

a. Resistors, capacitors, coils chokes, transformer winding, etc., fail.

b. Electrolytic action takes place in resistors, coils, chokes, transformer windings, etc, causing eventual break-down.

c. Moisture forms electrical leakage paths on terminal boards and insulating strips, causing flash-over.

d. Hook-up wire and cable insulation break down. Fungus growth accelerates deterioration.

29. TREATMENT.

A moistureproofing and fungiproofing treatment has been devised which, if properly applied, provides a reasonable degree of protection against fungus growth, insects, corrosion, salt spray, and moisture. The treatment involves the use of a moisture-and fungi-resistant varnish applied with a spray gun or brush Refer to TB SIG 13, Moistureproofing and Fungiproofing Signal Corps Equipment, for a detailed description of the varnish-spray method of moistureproofing and fungiproofing and the supplies and equipment required in this treatment.

CAUTION: Varnish or lacquer spray may have poisonous effects if inhaled. To avoid inhaling spray, use respirator if available. Otherwise, fasten cheesecloth or other cloth material over the nose and mouth

30. STEP-BY EP INSTRUCTIONS FOR TREATING SIGNAL GENERATOR TS-55/UP.

a. *Preparation.* Make all repairs and adjustments necessary for proper operation of the equipment.

b. *Disassembly.*

(1) Loosen four cover locks and remove the wooden cover.

(2) Loosen five captive thumb screws on the front panel and slide the chassis from the metal case.

(3) Turn the R.F. ATTENUATOR knob and the R.F. TUNING knob on the front panel to the extreme clockwise position.

(4) Remove the three screws mounting the power monitor meter and the metal shield to the front panel; remove the shield as far as the wiring will permit and disconnect the meter leads. Remove the meter.

(5) Disconnect the r-f cable connection at the cavity and pull the cable through the slot in the chassis to the under side.

(6) Loosen the tube clamps on the top side of the chassis

(7) Remove the screws from the side plates mounting the front panel to the chassis and remove the plates.

(8) Remove two clip type resistors (R45 and R27 and fuse (F2) from holders on the under side of the chassis.

(9) Remove the mounting screws from the terminal board near the capacitor (C21), the terminal boards for resistors (R45 and R27), and the terminal board mounting nine resistors (including R44). Pull the boards gently away from the chassis as far as the wiring will permit.

(10) Clean all dirt, dust, rust, fungus, oil, grease, etc, from the equipment.

c. *Masking.*

(1) The top side of the chassis (fig. 12) may be coated by either the brush or spray method.

(a) If the spray method is used, mask the following with masking tape:

1. Terminals on the meter leads (A).

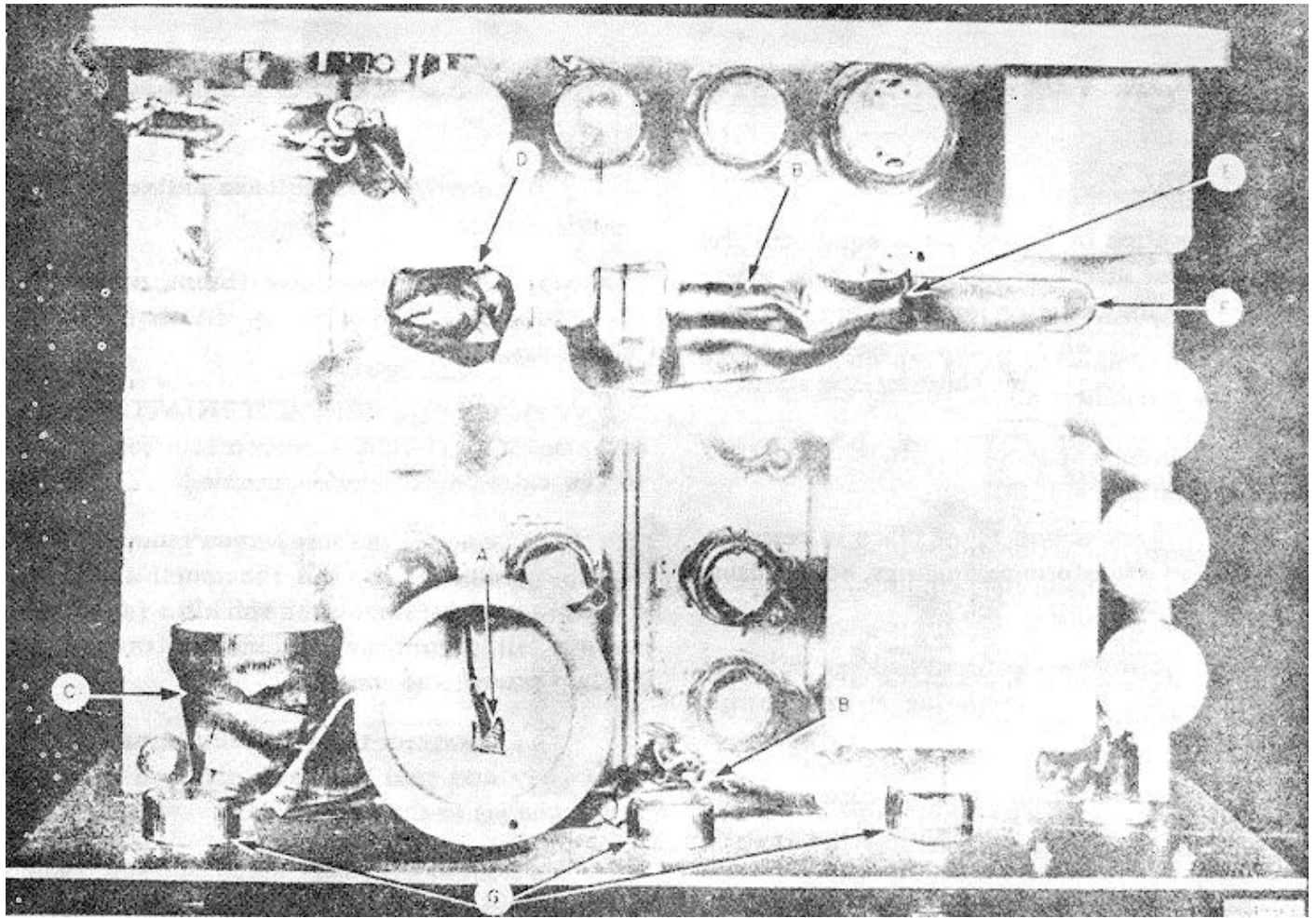

Figure 12. Masking, top of chassis

2. R-f attenuator gears on the rear of the front panel and on the cavity (B).

3. R-f tuning gears and moving shaft on the rear of the front panel (C).

4. Thermistor bridge assembly mounted on the cavity (D).

5. R-f input receptacle on the cavity (E).

6. Rubber grommets.

7. Setscrew holes.

8. Slot in the chassis at the end of the cavity (F).

9. Holes in the cases of the three potentiometers on the front panel (G).

(b) If the top side of the chassis is brush-coated, mask the r-f tuning gears and the r-f attenuator gears on the rear of the front panel.

(2) On the under side of the chassis (fig 13) mask the following with masking tape:

(a) Plug on the r-f input cable (H).

(b) Terminals for clip-type resistors (R45 and R27) and fuse (F2) (I).

(c) Contacts on calibration switch (S2) (J).

(d) Holes in the bases of the eight vacuum tube sockets.

(e) Rubber-covered cable (leaving cable termination exposed) (K).

(f) Rubber grommets

(g) Holes in the cases of the three potentiometers (J).

d. *Drying.* Dry the unit for six hours at 140°F.

e. *Varnishing.*

(1) Apply three coats of moistureproofing and fungiproofing varnish (Lacquer, Fungus-resistant, Spec. No. 71-2202, Stock No. 6G1005.3, or equal).

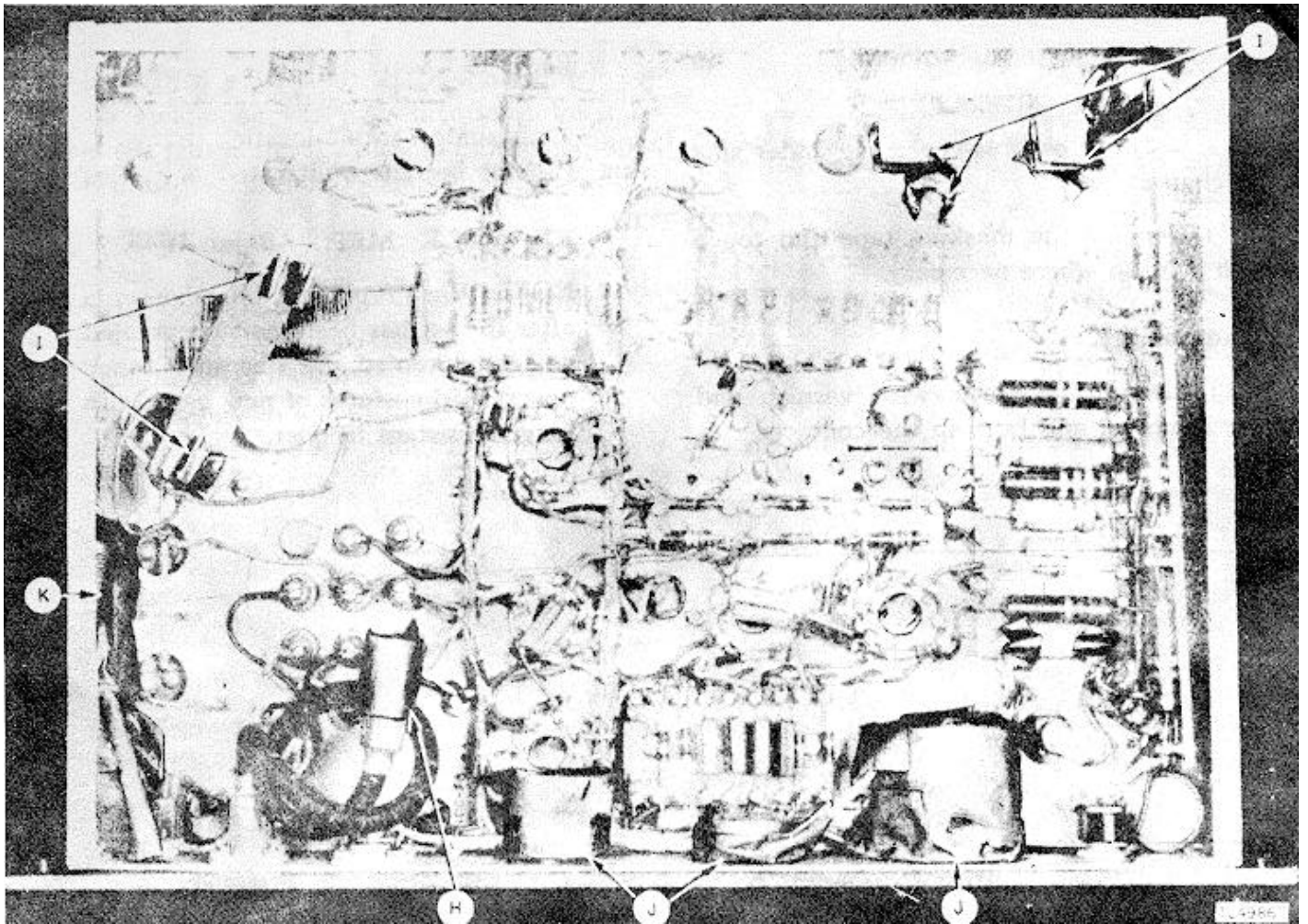

Figure 13. Masking, bottom of chassis

(a) If the spray method is used on the top side of the chassis, treat in the following manner.

1. Spray:
 - a. Vacuum tube bases and clamps.
 - b. Eight metal capacitor cans.
 - c. Three potentiometers (P5, P7, and P9).
 - d. Input trigger switch on the rear of the front panel.
 - e. Phenolic washers on the leads (cathode and filament) on the cavity.
 - f. All wiring and soldered connections.
 - g. Indicator light housing on the rear of the front panel.

2. Remove the masking from the thermistor bridge assembly and brush-coat the

wiring, the phenolic washers, and the stand-offs, the outer surface and edges of the bakelite mounting strips.

3. Brush-coat the surfaces of the bakelite meter case.

(b) If the brush-coat method is used on the top side of the chassis, treat in the following manner.

1. Brush-coat:
 - a. Vacuum tube bases and clamps.
 - b. Three potentiometers (P5, P7, and P9).
 - c. Eight capacitor cans.
 - d. Phenolic washers and stand-offs on the cavity and thermistor bridge assembly.
 - e. Bakelite case on the power monitor meter.

connections.

- f. All wiring and soldered connections.

- g. Indicator light housing.

- h. Input trigger switch.

(c) Spray or brush-coat the under side of the chassis.

(2) Remove the masking tape and touch up with a brush where necessary.

f. *Reassembly.*

(1) Clean all contacts with varnish and lacquer remover, and burnish the contacts.

(2) Reassemble the signal generator and test its operation.

g. *Marking.* Mark the letters MFP and the date of treatment near the nameplate on the equipment and in such a location that the marking will not become obliterated or rubbed off.

EXAMPLE: MFP – 8 Jan 1945.

NOTE: When replacing defective parts after the set has been moistureproofed and fungiproofed, use a brush to touch up exposed surfaces of new parts with fungus-resistant lacquer.

**PART FOUR
AUXILIARY EQUIPMENT**

NOT USED

**PART FIVE
REPAIR INSTRUCTIONS**

NOTE: Failure or unsatisfactory performance of equipment used by Army Ground Forces and Army Service Forces will be reported on W.D., AG.O. Form No. 468 (Unsatisfactory Equipment Report).

If Form No. 468 is not available, see TM 38-250. Failure or unsatisfactory performance of equipment used by Army Air Forces will be reported on Army Air Forces Form No. 54 (Unsatisfactory Report).

SECTION IX – THEORY OF OPERATION

31. GENERAL DESCRIPTION.

a. *Mechanical.*

(1) The structure of Signal Generator TS-155/UP consists of a typical radio chassis on which all circuit parts are mounted. It is conventional except for

the cavity and its associated parts. These are easily accessible for replacement. The chassis is secured to the front panel. This unit slides into a dust cover or protective box where it is held by means of the captive screws as shown in figure 6. The support bar shown in figure 10 allows the chassis to be inverted and placed on a bench for inspection of the components.

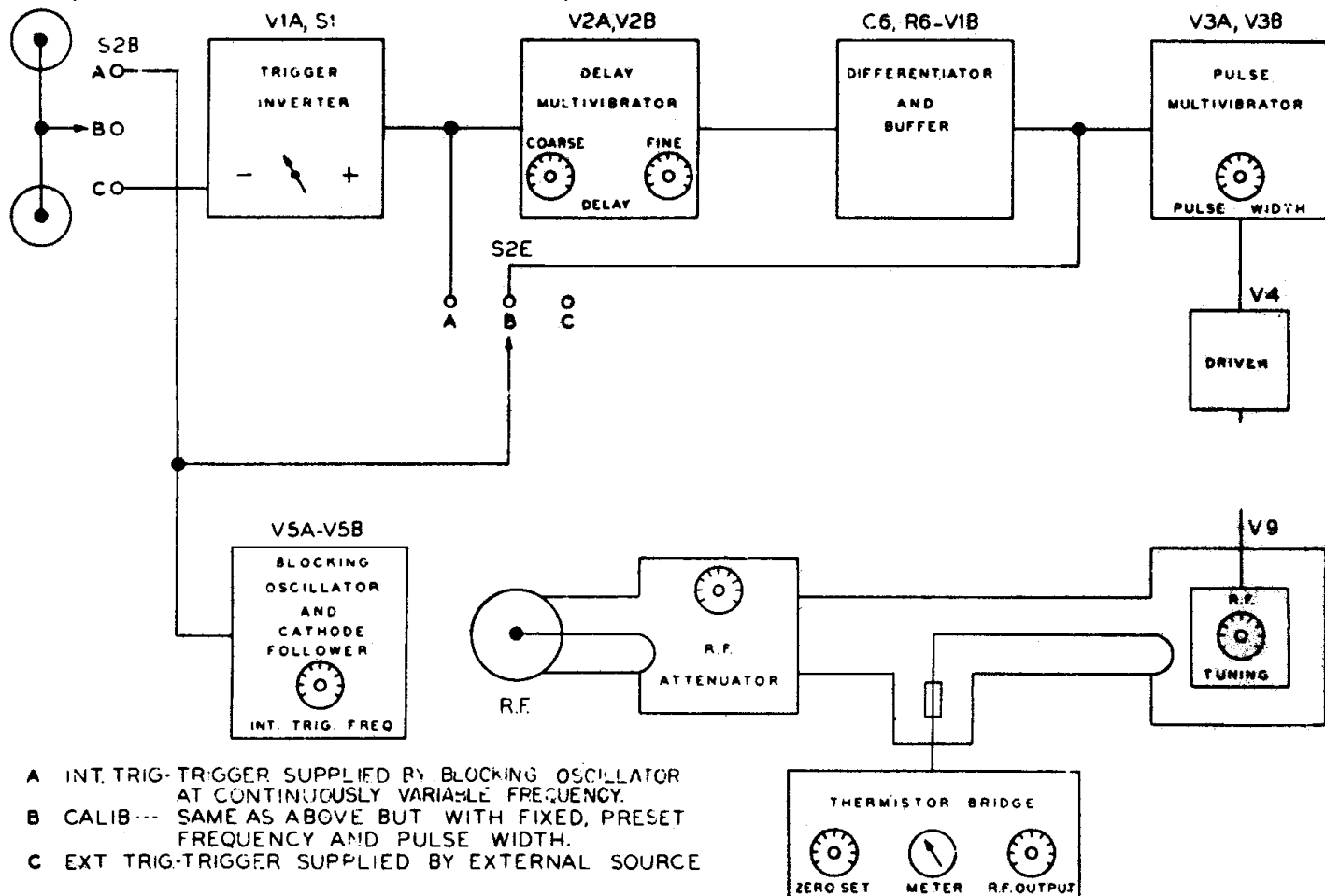

TL49868

Figure 14. Signal Generator TS-155/UP, block diagram.

(2) The cavity and its associated parts are made up of the following:

- (a) Cavity.
- (b) Thermistor monitoring system.
- (c) Attenuator.

b. *Electrical.* The simplified block diagram (fig. 14) shows the relationship between the principal component circuits, with the exception of the power supply. These parts and their functions are as follows:

(1) *Blocking Oscillator.* Provides a signal at the desired repetition rate for triggering the signal generator internally.

(2) *Trigger Inverter.* Takes a positive or negative external signal and applies it to the delay multivibrator with proper polarity for triggering the signal generator from an external source.

(3) *Delay Multivibrator.* This stage is triggered by a signal from either the trigger inverter or the blocking oscillator. It provides a square or rectangular pulse, the length of which determines the time delay between the triggering signal and the final r-f pulse.

(4) *Differentiator and Buffer.* Converts the trailing edge of the delay multivibrator pulse into a signal for triggering the pulse multivibrator.

(5) *Pulse Multivibrator.* When triggered, it provides a pulse of desired duration for keying the cavity oscillator.

(6) *Driver.* Shapes the pulse developed in the pulse multivibrator so that it may properly key or modulate the cavity oscillator.

(7) *Cavity Oscillator.* When keyed or modulated, the cavity oscillator provides the r-f power.

(8) *Thermistor Bridge.* Measures r-f power passing through the r-f attenuator.

(9) *R-f Attenuator.* Controls the output power from the cavity oscillator. It is also used to pass power from an external source to the thermistor bridge for measurement.

(10) *Power Supply.* Supplies power to energize the circuits.

32. DESCRIPTION OF MECHANISM OF CAVITY AND ASSOCIATED PARTS.

The principal parts of this complete assembly consist of the cavity proper, the thermistor monitoring system, and the attenuator. These parts are interconnected mechanically, thus forming a sub-assembly which may be removed as a unit from the chassis. Two types of cavities are employed, namely the "AO" (Auto Ordnance) in the TS-155/UP and the "PR" (Presto Recording) in the TS-155A/UP (fig. 3). These two types are fundamentally the same in their mechanical and electrical features although they differ somewhat in mounting dimensions. The following description of the cavity and associated parts shown in figure 15 is sufficiently general to apply to both types. Figure 15 presents a disassembled view of the cavity and associated parts. Figure 10 shows the cavity and associated parts assembled and mounted on the chassis.

a. *Cavity.* The cavity proper consists of a silver-plated brass tube. Within this tube are located the following: the tall piece which supports the type 446B or 2C40 oscillator tube; the grid cylinder sleeve assembly which slips over the grid ring of the type 446B or 2C40 tube; the grid leak which contacts the grid cylinder sleeve assembly; the cathode fingers which are a ring of flexible metal fingers located within the cavity proper and which contact the cathode ring of the type 446B or 2C40 tube; the plunger which carries an outer ring of fingers that contact the inside wall of the cavity proper and an inner ring of fingers that contact the plate tuning shaft; and the plate tuning shaft which is moved along its axis by means of the worm and the sliding drive yoke when the tuning dial is rotated.

(1) The dimensions of the cavity proper are chosen to permit stable oscillations over the band of frequencies identified as the S-band. The grid cylinder sleeve assembly and the plunger are adjustable. This permits setting the oscillator frequency to a subdivision of the S-band, e.g., Sa or Sg band, and also provides means for controlling the feedback portion of the oscillator circuit. Fine tuning within each subdivision of the S-band is accomplished by moving the plate cap fingers of the plate tuning shaft over the plate cap of the type 446B or 2C40 oscillator tube.

(2) The tail piece may be readily removed from the cavity proper and therefore permits

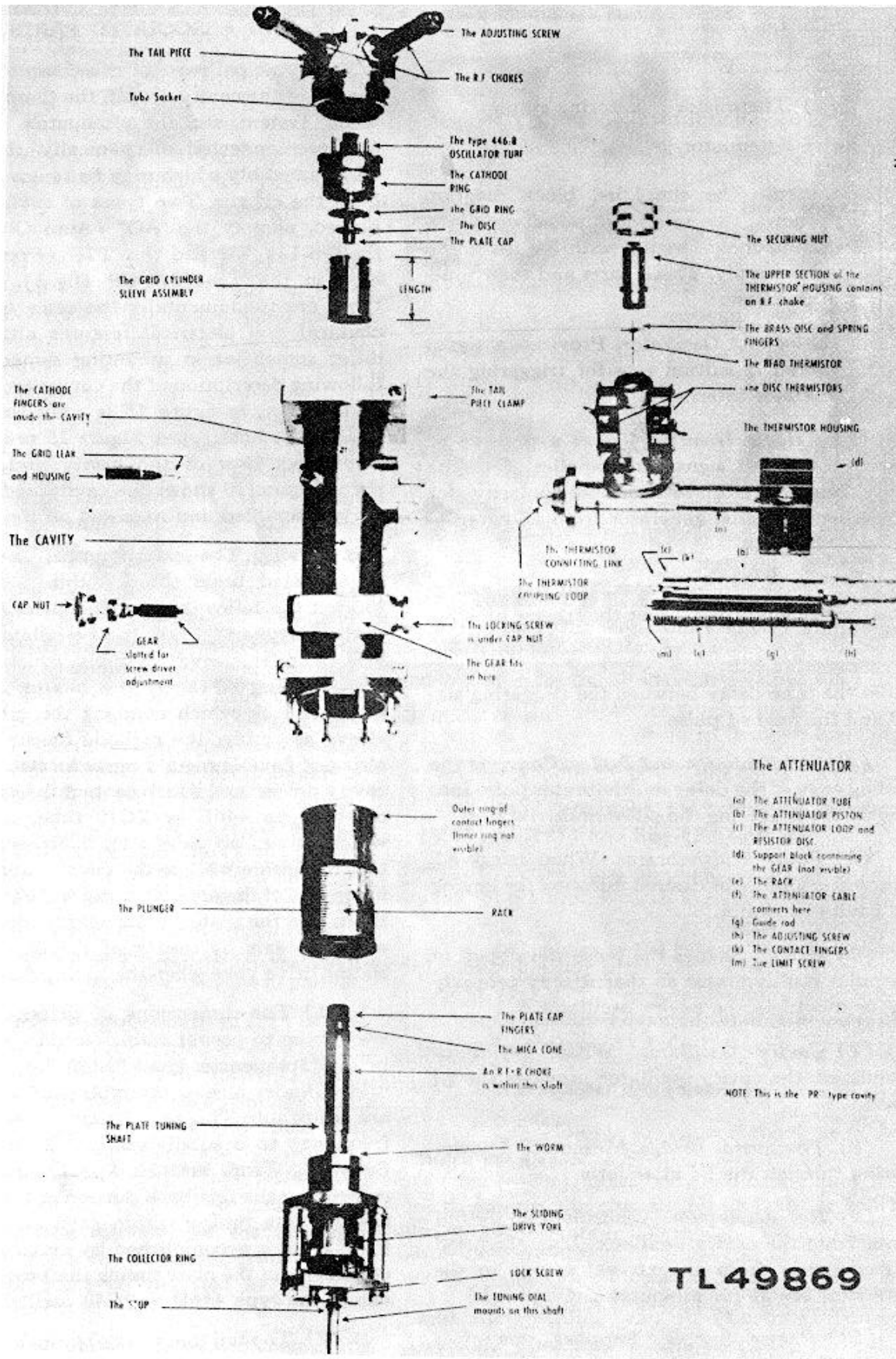

Figure 15. Disassembled cavity

easy access to the type 446B or 2C40 oscillator tube for replacement purposes. It serves to support the tube by means of the tube socket. Many of these tubes are structurally imperfect with respect to mechanical alignment of the elements. The adjusting screw is provided in the end of the tall piece to allow the tube to be aligned physically within the cavity, so that the plate cap fingers may move freely on the plate cap of the tube. The r-f chokes on the tall piece serve to filter the cathode and filament leads.

(3) The B-designation of the type 446B tube identifies it as specially selected for use as an oscillator in the operating frequency range of this equipment. The type 2C40 tube is a similar tube made to more rigid specifications. The cathode ring of the tube fits into the cathode fingers making up one end of the cavity.

(4) The grid cylinder sleeve assembly is made up of a main cylinder with flexible fingers which slip over the grid ring of the tube and a companion split cylinder which grips the main cylinder. The length of this assembly may be varied for optimum operating conditions.

(5) The grid leak is contained within a metal housing which threads in a boss on the cavity proper. When so located the grid leak contacts the grid cylinder sleeve assembly.

(6) The plunger with its outer and inner ring of contacting fingers forms the other end of the cavity. It may be moved within the cavity proper by means of the plunger gear and rack. The end of the gear shaft is slotted for adjustment with a screwdriver. When assembled in the cavity proper, the plunger gear fits into the rack and the cap nut covers this mechanism. When the optimum position of the plunger within the cavity has been determined, it may be locked in position by a locking screw.

(7) The plate tuning shaft mechanism serves to move the plate cap fingers over the plate cap of the oscillator tube. When the tuning dial shaft is rotated, this rotary motion is imparted to the plate tuning shaft through the sliding drive yoke. Through the medium of the worm, the plate tuning shaft is moved along its axis as it is rotated, thus moving the plate cap fingers on the plate cap of the oscillator tube in a spiral manner. Both the end of the plate cap finger unit and

the end of the plate tuning shaft into which it fits are conical. A mica cone separates and insulates these pieces and forms a bypass capacitor. The plate tuning shaft is hollow and contains an insulated brass rod which connects the plate cap finger unit to the collector ring. The B + voltage is connected to a brush which contacts the collector ring and through the brass rod carries the plate voltage to the oscillator tube. An r-f choke is also located within the hollow plate tuning shaft and filters the B + line.

(8) The stop on the front end of the cavity serves to limit the travel of the plate cap fingers over the plate cap of the oscillator tube. The length of this travel for tuning purposes is 3/16 inch and is obtained when the tuning dial is rotated 270 ° (100 divisions), the worm having four threads per inch.

(9) The type 446B or 2C40 tubes vary in their heights. Compensation for this variation may be obtained by displacing the operating region of the plate tuning shaft. When the lock screw of the stop is released, the plate tuning shaft may be rotated approximately 1 1/2 revolutions (540°), which corresponds to a travel of 3/8 inch. This additional 3/16 inch of travel provides sufficient displacement of the operating region of the plate tuning shaft to compensate for variations in the heights of the type 446B or 2C40 tubes.

b. Thermistor Monitoring System. The principal parts are the thermistor coupling loop, the thermistor connecting link, the two disk thermistors, the bead thermistor, and the housing for the thermistors.

(1) R-f power is taken from the cavity for the thermistor monitoring system by the thermistor coupling loop which penetrates the cavity proper. The extension of the wire which forms the loop passes into the thermistor connecting link (a brass tube) and is connected at right angles to one end of a tapered brass rod which in turn is mounted within the thermistor housing. The other end of the tapered brass rod is slotted to permit insertion of one lead of the bead thermistor. The other lead of the bead thermistor is inserted through a hole in the center of a small brass disk to which is secured a set of small spring fingers that contact this lead of the bead thermistor. The conical end of another brass rod fits over the spring fingers of the small brass disk. This brass rod is held within the upper section

of the thermistor housing, is insulated from it, and terminates in a terminal post. An r-f choke is contained in this upper section of the thermistor housing.

(2) The r-f power is monitored by the change of resistance of the bead thermistor caused by the r-f current passing through and heating it. The disk thermistors are secured to the sides of the thermistor housing, and serve to compensate any change of resistance of the bead thermistor due to ambient temperature changes.

(3) The tapered brass rod serves to match the impedance of the thermistor coupling loop to that of the bead thermistor.

(4) The thermistor connecting link is a silver-plated brass tube through which the thermistor coupling loop wire passes to connect to the tapered brass rod. It also serves to support the attenuator. The length of the thermistor coupling loop wire is critical and its length together with the length of the thermistor coupling link differs for each subdivision of the S-band.

(5) The small brass disk described above serves as an r-f bypass capacitor and, together with the r-f choke, filters this line. A lead from the thermistor bridge circuit is connected to the terminal post.

(6) The r-f chokes consist of powdered iron cores which are slipped over the brass rods and are insulated from the grounded frame of the cavity assembly.

c. *Attenuator.* The principal parts of the attenuator are the attenuator tube, the piston, the gear and rack, and the attenuator loop.

(1) The attenuator tube is a silver tube which is threaded into the thermistor connecting link and serves to guide the piston. Silver is used to insure good conductivity through the contact fingers of the piston.

(2) The piston travels within the attenuator tube. It contains an insulated brass rod which terminates at one end in the attenuator loop and resistor disk. The resistor disk is not visible in figure 15 but is located close to the attenuator loop. It consists of a thin bakelite disk which has been sprayed on one surface with a resistive material. The brass rod passes through the center of this disk, contacting the resistive material. The outer edge of this disk contacts the inner surface of

the piston. The function of the resistor disk is to terminate the transmission line (*i.e.*, the brass rod and the attenuator loop) in its proper impedance. The other end of the insulated brass rod is connected to a jack to which a flexible output cable (not shown) connects. The other end of the output cable connects to the R.F. jack which is located on the front panel. The piston is actuated from the attenuator dial on the front panel (fig. 6) by means of the gear and rack.

(3) The attenuator loop couples to the r-f line within the thermistor connecting link and housing. Since the r-f power is monitored, the attenuator may be calibrated, and a known r-f power will be delivered to the proper impedance at the R.F. jack.

(4) The adjusting screw of the attenuator limits the maximum coupling between the attenuator loop and the thermistor coupling loop wire.

CAUTION: *This adjusting screw is factory adjusted and locked in position and should not be changed as this would affect the calibration of the attenuator.*

33. ANALOGY OF CAVITY OSC TO LUMPED CIRCUIT OSC.

a. The oscillator circuit consists of the type 446B or 2C40 tube elements and the resonant cavity in which the tube is mounted. If the resonant cavity is considered to be composed of three coaxial line cavity parts, A, B, and C as shown in figure 16, it can be compared with a somewhat analogous lumped constant circuit shown in figure 17. This type of resonant cavity provides large feedback between the plate to grid region and the grid to cathode region, so that oscillations build up quickly at the beginning of each pulse.

b. The components shown in the diagram, figure 16, can be compared to the lumped constant circuit of figure 17 by referring to the corresponding circled identification letters on the illustrations.

c. The R.F. TUNING control (F) changes the frequency by moving the plate cap fingers along the plate cap of the 446B or 2C40 tube which

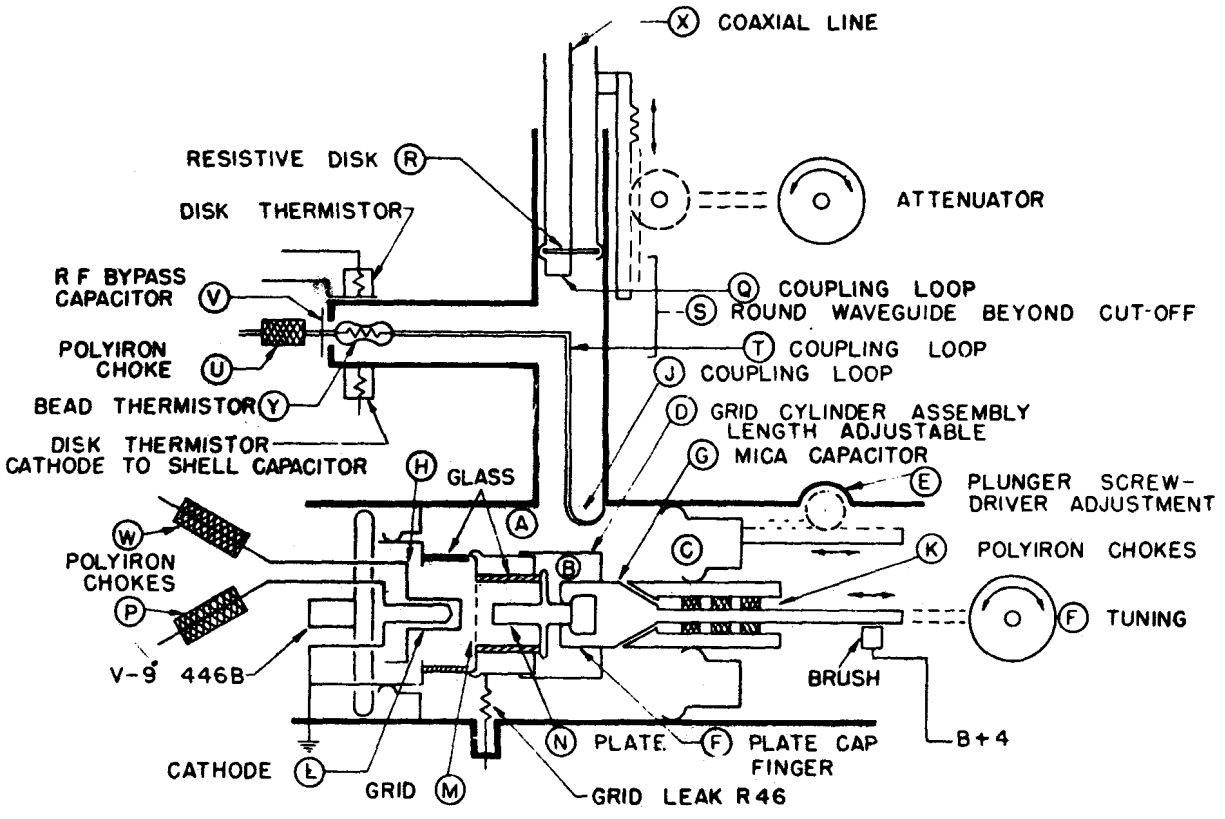

TL49881

Figure 16. Schematic diagram of cavity

FOR PURPOSES OF SIMPLIFIED ILLUSTRATION THE TUNING ELEMENTS OF THE COMPLEX RESONANT CAVITY ARE SHOWN AS CAPACITORS IN THIS EQUIVALENT CIRCUIT.

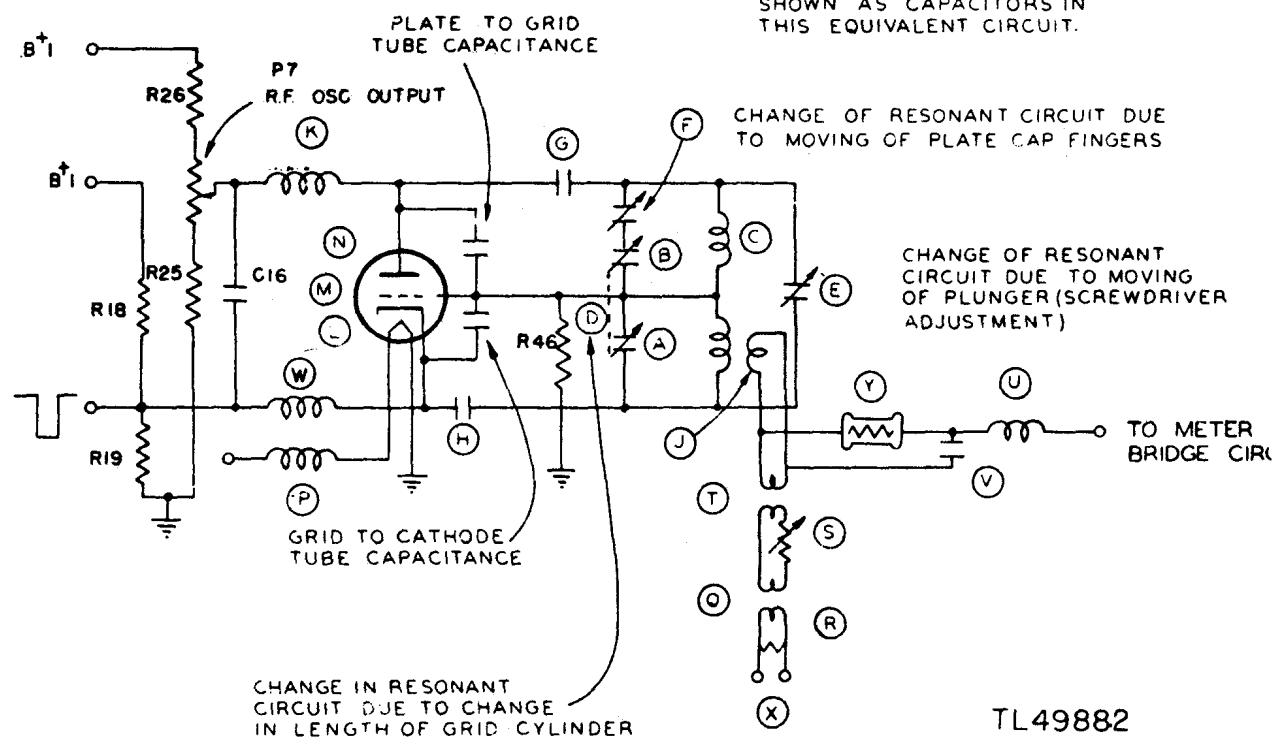

TL49882

Figure 17. Equivalent circuit of cavity

changes the plate to grid region of the resonant cavity. The power output is adjusted by changing the plate voltage with the R.F. OSC OUTPUT potentiometer P7 shown in figure 29. When a tube is replaced, the length of the grid cylinder assembly (D) must be adjusted to compensate for the variations of the interelectrode capacities between tubes so that the proper frequency range may be covered. Each time the grid cylinder assembly is readjusted, the plunger (E) must be adjusted for maximum power output.

d. Three polyiron chokes (K) are installed to prevent leakage of r-f power from the cavity along the d-c leads.

34. ELECTRICAL DESCRIPTION OF COMPONENTS.

a. Blocking Oscillator.

(1) The blocking oscillator provides a triggering signal of the desired repetition rate when the selector switch is in CALIB or INT TRIG position. The basic blocking oscillator circuit is shown in figure 18.

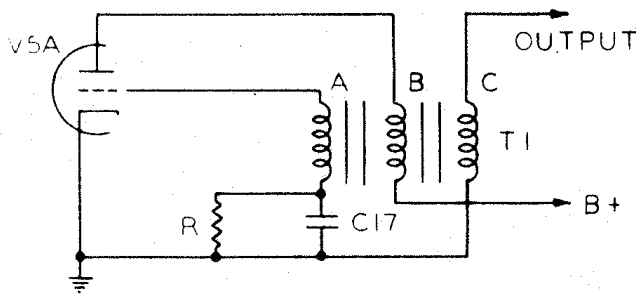

TL49870

Figure 18. Basic blocking oscillator circuit

When the B + voltage is applied, the tube (V5A) becomes conducting because the grid is initially at zero voltage. The flow of electrons through winding B of transformer T1 sets up a voltage across winding A, causing a flow of electrons from one plate of capacitor C17 through resistor R. This makes the grid side of capacitor C17 positive, thus increasing the plate current, as shown in figure 19.

As saturation is approached, the induced voltage across winding A decreases. This causes the grid voltage to become less positive, causing less plate current to flow. The decrease in plate current through winding B induces a voltage in the opposite direction in winding A, causing

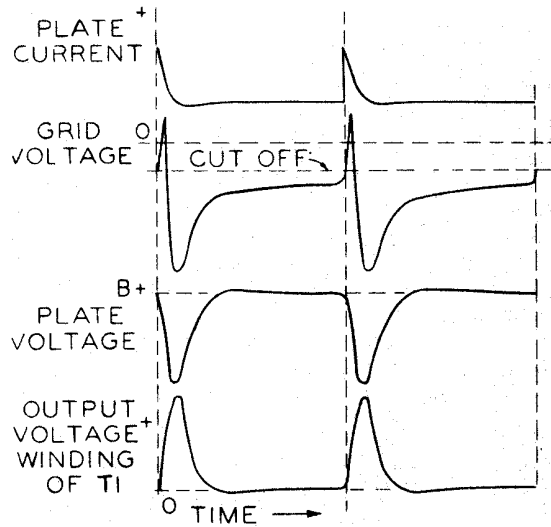

TL49871

Figure 19. Blocking oscillator waveforms

electrons to flow to the grid side of capacitor C17. This makes the grid negative beyond cut-off. The resultant voltage across the output winding C is a single cycle of oscillation as shown in figure 19. This cycle is repeated when capacitor C17 discharges to the point where the grid voltage passes the cut-off point and the tube again becomes conducting. This time of discharge and, therefore, the repetition rate may be controlled by adjusting the values of the resistor and capacitor. See figure 20.

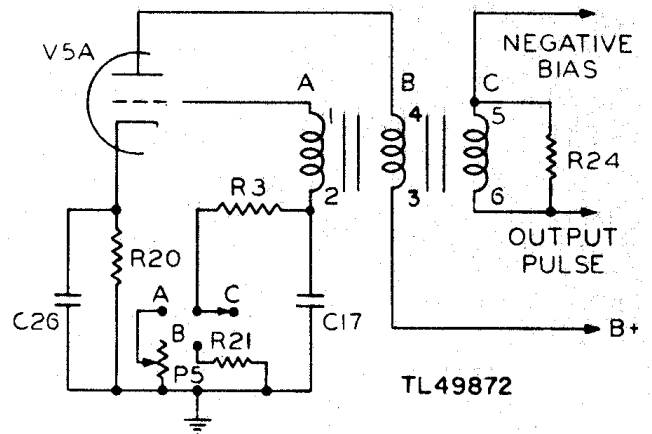

TL49872

NOTE:

IN SOME EARLY DEVELOPMENT EQUIPMENTS, THE NUMBERING OF TERMINALS 3 AND 4 IS REVERSED

Figure 20. Blocking oscillator circuit

(2) When the selector switch is in the CALIB position, R (fig 18) is composed of resistors R3 and R21. These values have been chosen for a repetition rate of approximately 800 cycles per second. When the selector switch is

in the INT TRIG position, R consists of resistor R3 and potentiometer PS. Variation of the potentiometer adjusts for repetition rates between 120 and 2,000 cycles per second. When the selector switch is in EXT TRIG position, the grid is biased beyond cut-off so that the blocking oscillator is inoperative.

(3) The cathode-follower section (V5B) with the selector switch in the INT TRIG position is used to supply a positive pulse to the TRIGGER jacks for triggering external equipment (fig. 21). It also supplies a negative pulse for triggering the delay multivibrator through the trigger inverter section. With the selector switch in CALIB position, a positive pulse is applied to the pulse multivibrator through the buffer tube section V1B.

(a) The cathode follower (fig. 21) is a degenerative vacuum tube circuit in which degeneration is produced by an unbypassed cathode resistor; the output is taken across this resistor.

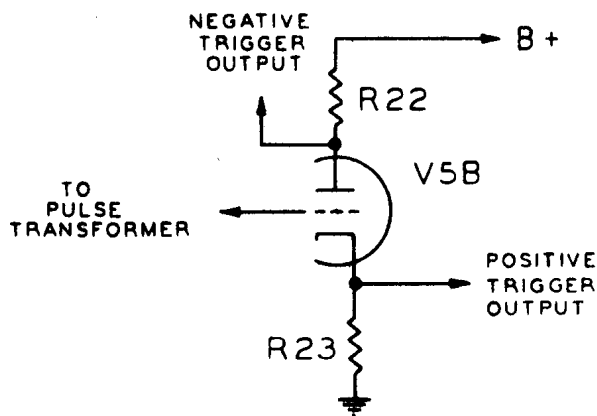

TL49873

Figure 21. Cathode-follower circuit

This circuit is essentially an impedance matching device with less than unity voltage gain but possessing power gain. Its high input impedance and very low output impedance render it particularly suitable for coupling a pulse generating stage to a transmission line. The pulses from the blocking oscillator transformer are applied to the negatively biased grid of V5B. Cathode resistor R23 is unbypassed so that when the grid voltage increases (*i.e.*, becomes more positive or less negative), the corresponding increase in cathode current develops a voltage across resistor R23 which is in phase with the voltage applied to the grid but smaller in magnitude. The voltage across resistor R23 produces degeneration

(inverse feedback) by decreasing the voltage from grid to cathode. The voltage across resistor R23 is coupled through capacitor C18 (fig. 29) to the TRIGGER jacks when the selector switch is in the INT TRIG position, making it available for triggering external equipment. This voltage is also coupled through capacitor C4 to the grid of V1A where it is used to trigger the pulse circuits

(b) When the grid voltage of V5B increases, the increased plate current through resistor R22 increases the voltage drop across that resistor, lowering the plate voltage so, that the positive pulse on the grid is transformed to a negative pulse at the plate. The negative pulse is coupled through capacitor C3 to the cathode of V1A when the switch is in the INT TRIG position. where it acts with the pulse coupled to the grid to trigger the pulse circuits.

(c) With the selector switch in CALIB position, the positive pulse from the cathode resistor R23 is coupled through C4 to the buffer tube section V1B.

b. Trigger Inverter. With the selector switch in EXT TRIG position, the delay multivibrator is triggered with a signal of the correct polarity, whether the input trigger is positive or negative, by means of the trigger inverter (fig. 29)

(1) *Negative Trigger.* When the input trigger polarity switch (S1) is in the - (minus) position. the negative trigger is coupled to the cathode (pin 6) of the delay multivibrator input tube V1A. This drives the cathode negative, which is equivalent to driving the grid more positive. The trigger signal appears at the plate of V1A as a negative pulse.

(2) *Positive Trigger.* When the input trigger polarity switch (S1) is in the + (plus) position, the positive trigger is coupled to the grid (pin 4) of the delay multivibrator input tube V1A. The trigger signal appears at the plate of V1A as a negative pulse.

c. *Delay Multivibrator (fig. 22).*

(1) During the intervals between triggers, V2B is conducting; its grid is at zero potential with respect to its cathode. The plate current of V2B passing through RS biases V2A beyond cut-off. This situation is

maintained until a trigger is applied, as shown in figure 23-2.

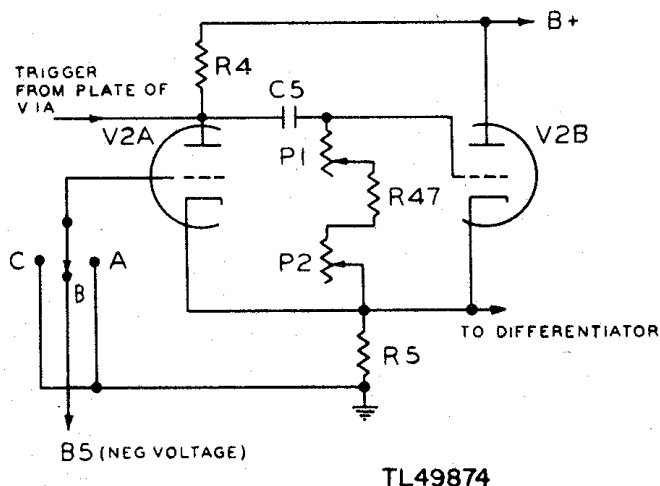

Figure 22 Delay multivibrator circuit

(2) When a trigger is applied to the input tube, V1A, it causes V1A to conduct. The plates of V1A and V2A are tied together. Because of this, a drop in the potential at the plate of V2A is produced when the plate current of V1A passes through R4 (fig. 23-3).

(3) Since the potential difference across capacitor C5 cannot change instantaneously, the potential of the grid of V2B drops together with that of the plate of V2A (fig. 23-4). This decreases the plate current through V2B and decreases the negative bias on V2A sufficiently to allow V2A to conduct. The plate current through V2A produces a drop across R4, reinforcing the original drop in voltage at the plate of V2A. This new drop in voltage at the plate of V2A is again transmitted through capacitor C5 to the grid of V2B. The process continues until V2B is completely cut off, while V2A is conducting.

(4) Thus, the arrival of the trigger does two things simultaneously: stops the current through V2B and starts the current through V2A. The current through V2A will be much less than the current through V2B (when conducting) because of the presence of R4 in the plate circuit of V2A. Therefore, the potential drop across R5 decreases since the plate currents of both V2A and V2B pass through that resistor.

(5) The grid of V2B will remain below cut-off while capacitor C5 discharges through the series-resistance combination of P1, R47, and P2. The time of discharge will depend upon the time constant of the capacitance-resistance (C5 and P1, R47, P2)

combination. As soon as the grid of V2B reaches the cut-off point, V2B begins to conduct. The current through V2B, passing through R5, increases the negative bias on the grid of V2A, thereby decreasing the current through V2A. The decrease in V2A current through R4 causes the voltage at the plate of V2A to rise. This rise is transmitted through capacitor C5 to the grid of V2B, whose potential is raised still further above cut-off. This cycle of events is repeated until V2A is cut off completely, while V2B is once again conducting. Thus the conditions preceding the arrival of the pulse are reestablished and maintained until the arrival of the next pulse.

(6) The output (fig. 23-5) of the multivibrator is the voltage across R5. As explained above, the voltage across R5 drops suddenly upon the arrival of a trigger, and then just as suddenly rises when C5 discharges sufficiently to permit V2B to conduct. The minimum delay obtainable is determined by R47 and the residual resistance of P1 and P2.

d. Differentiator.

(1) The differentiating circuit (fig. 24) converts the rectangular pulses from tube V2B into negative and positive pulses by the RC differentiator consisting of C6 and R6. The RC time constant is small compared to the length of the input pulse. This enables capacitor C6 to discharge quickly after each change in cathode voltage of tube V2B.

(2) Since V1B, the pulse width multivibrator input tube, is normally nonconducting, the negative trigger resulting from the leading edge of the pulse from V2B does not affect it. The positive pulse from the differentiator resulting from the trailing edge of the pulse from V2B causes tube V1B to conduct, thus triggering the pulse width multivibrator at a time delay after the input trigger equal to the width of the delay multivibrator pulse previously described.

(3) Thus the rectangular pulse produced by the delay multivibrator is converted into a short negative pulse followed by a short positive pulse, separated by the width of the rectangular pulse. The width of this rectangular pulse is controlled by the pulse delay controls P1 (coarse)

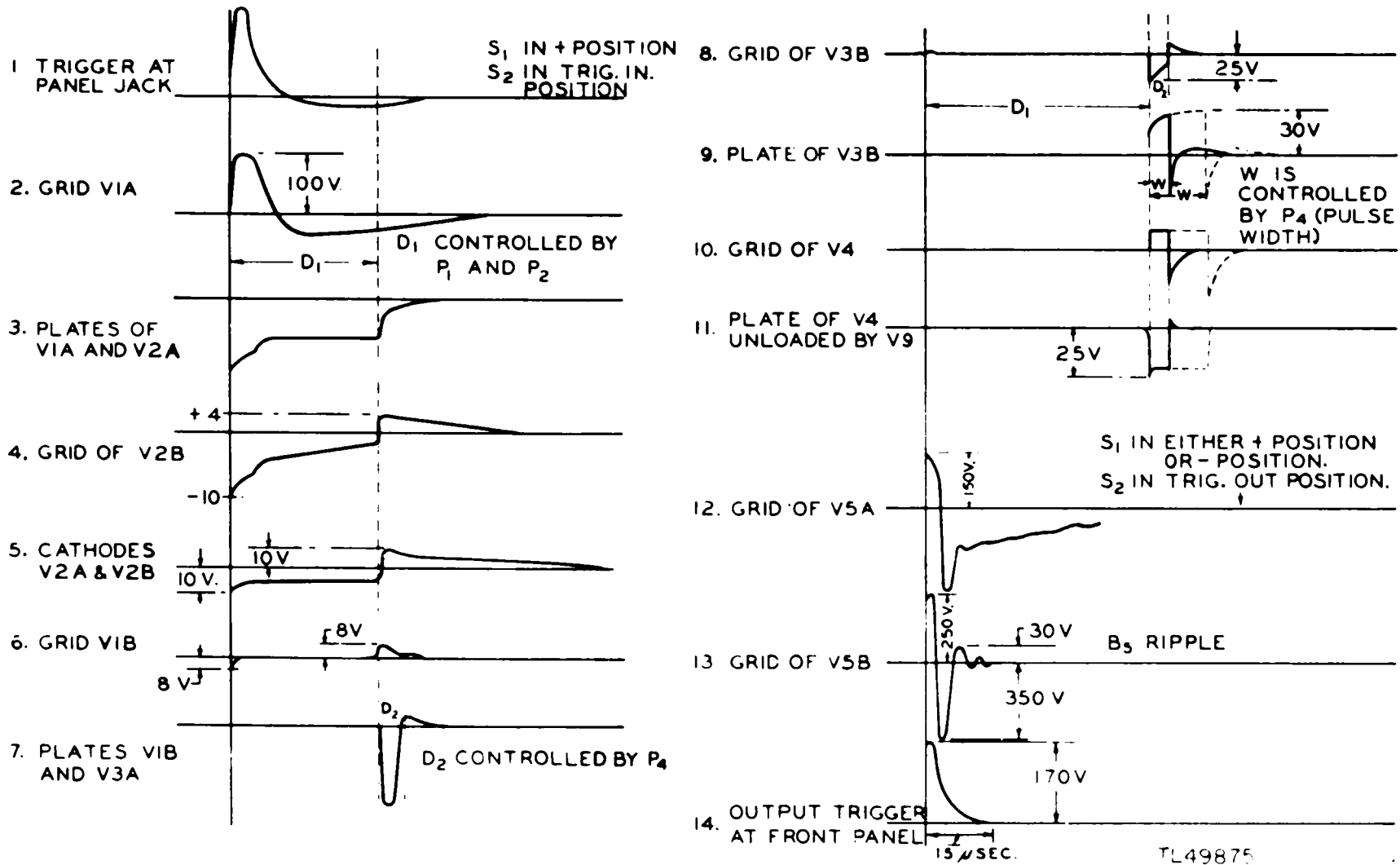
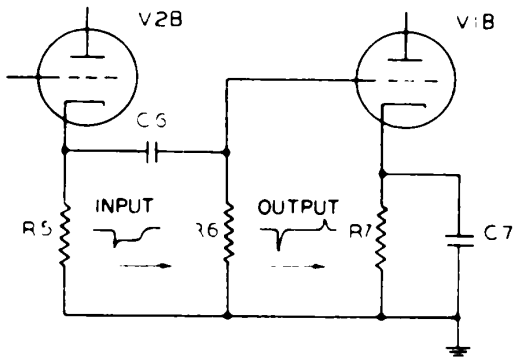

Figure 23. Waveforms.



TL49876

Figure 24. Differentiator circuit.

and P2 (fine). The negative pulse corresponds to the time of the trigger obtained from the transmitter. The positive pulse triggers the pulse multivibrator tube V3 through the input tube V1B.

e. Pulse Multivibrator (fig. 25). The positive pulse from the differentiating circuit in triggering the pulse multivibrator tube V3 (through the input tube V1B), produces a rectangular wave output whose width is variable by means of the pulse width control P4; control P3 adjusts the calibrate pulse width. This rectangular pulse is passed on to the V4 driver tube.

(1) In the absence of a triggering signal, V3B is conducting. During this time V3A is nonconducting, being biased beyond cut-off by the negative voltage from the fixed bias supply. When a

positive trigger (fig. 23-6) from the output of the differentiator is applied to the input tube V1B of the pulse multivibrator, it causes a sudden drop in the voltage at the plate of V3A (fig. 23-7). This drop is transmitted through capacitor C8 to the grid of V3B (fig. 23-8). This causes the current through V3B to decrease and the plate voltage of V3B to rise. The latter rise is transmitted through capacitor C9 to the grid of V3A, carrying this grid past cut-off. This starts and increases the current through V3A and further decreases the voltage at the plate of V3A. This process continues until V3B is cut off. V3B remains cut off until C8 discharges through R12 and P3 or P4 (depending on the position of the selector switch) sufficiently for the potential of the grid to rise to cut-off. V3B then starts to conduct, and the reverse of the process just described takes place until V3A is cut off and V3B is conducting. The length of the output pulse (fig. 23-9), which is taken from the plate of V3B, depends on the time constant of the resistance-capacitance combination C8, R12, and either P3 or P4.

(2) The resistance-capacitance combination (R10, C10) acts as a decoupler. The r-f choke L1 helps to square the output pulse.

(3) The minimum pulse width obtainable will be determined by the value of R12.

f. Driver (Modulator and Pulse Shaper). The rectangular pulse developed in the pulse multivibrator

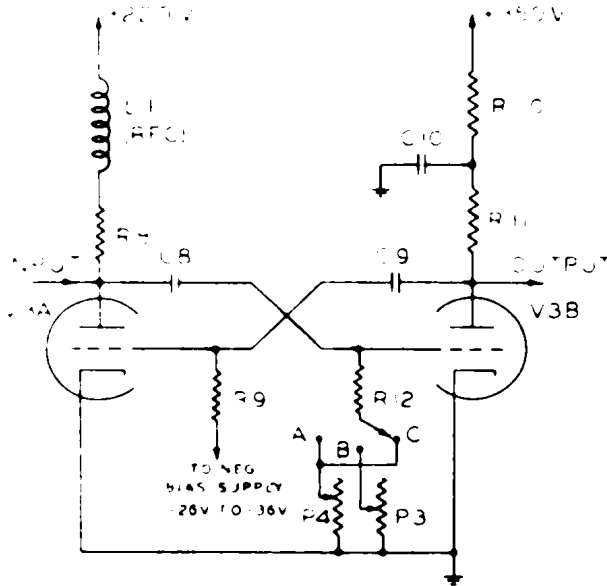

TL49877

Figure 25. Pulse multivibrator circuit.

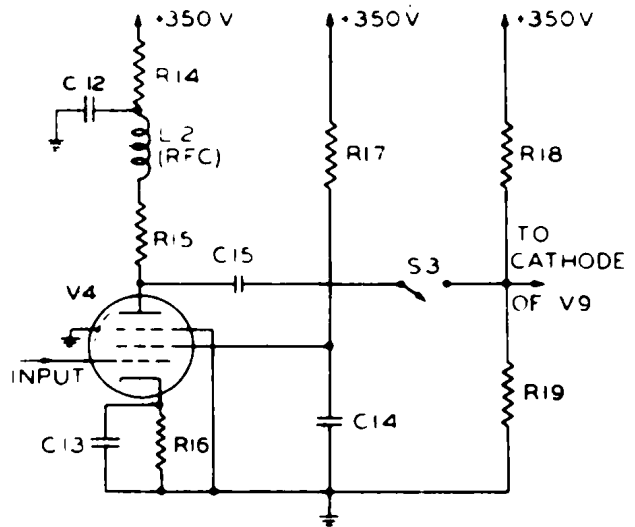

TL49878

Figure 26. Pulse modulator circuit.

is amplified and shaped by tube V4. The shaping consists of improving the squareness of the pulse. This stage consists of the pentode amplifier tube V4 shown in figure 26. The internal shield and the suppressor grid are tied to ground. Screen voltage is supplied through a dropping resistor R17 which is bypassed by C14. C12 is the plate bypass capacitor. The output of V4 (plate, pin 8) (fig. 23-11) is a negative rectangular pulse which is coupled to both cathode and plate of oscillator tube V9 through capacitor C15, when the R.F. OSC switch, S3, is in the ON position.

g. Cavity Oscillator Tube. The cathode of V9 (cavity oscillator tube) is positively biased by the voltage divider (R18, R19). This is equivalent to a negative bias beyond cut-off on the grid and keeps tube V9 from oscillating when it is not keyed by the output pulse of V4. The negative pulse from the output of V4 (plate, pin 8) on the cathode of V9 momentarily raises the grid above cut-off and permits the tube to oscillate. This produces a train of r-f oscillations, with a rectangular envelope, whose duration is equal to the width of the modulating pulse.

h. Thermistor Bridge. The thermistor bridge measures power by use of a variable resistance element, a thermistor, in a bridge circuit. The thermistor resistance decreases with increasing temperature and vice versa. Changes of thermistor temperature and, hence, resistance may be caused by thermal changes in its environment, by a-c or d-c currents flowing through it, or by absorbed r-f power.

(1) *Basic Thermistor Bridge Circuit.*

(a) There are two classes of thermistors used in the signal generator (fig. 27). The bead thermistor used for power measurement has a small mass and is affected by the changes mentioned above. The disk thermistor used in compensating networks has a large mass and its resistance is relatively insensitive to the current flowing through it. It is mounted on the outside of the cavity and its resistance is dependent primarily on the ambient temperature. A simplified thermistor bridge circuit is shown in figure 28-A. The Wheatstone bridge consists of resistors R32, R33, R34 and bead thermistor R35. No current flows in meter M when the Wheatstone bridge is balanced. The bridge is balanced when the resistances meet the

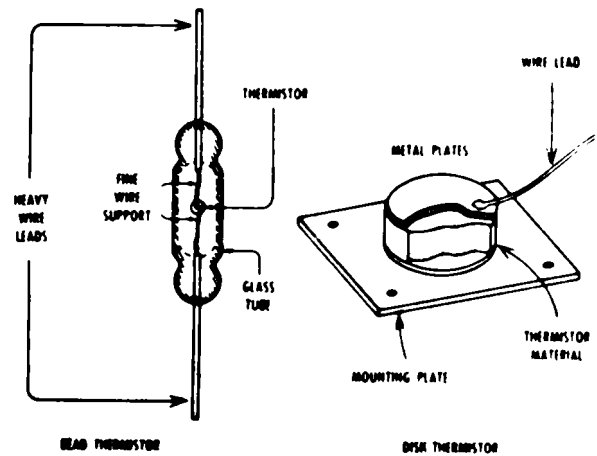

TL49879
Figure 27. Thermistors.

following conditions:

$$\frac{R34}{R35} = \frac{R32}{R33}$$

The bridge is balanced with no r-f power heating the thermistor bead (R35) by adjusting the METER ZERO SET control P9 which varies the current in bead thermistor R35, changing the thermistor temperature. Since the thermistor resistance changes with temperature, the resistance of bead thermistor R35 can be adjusted by the METER ZERO SET control P9 to meet the balance condition of the above equation.

(b) After meter M has been set to zero reading, r-f power can be measured by feeding the power into the waveguide through the R.F. jack or from the cavity. The r-f power absorbed by the thermistor, increases its temperature, decreasing its resistance and unbalancing the bridge so that current flows through meter M. The current flowing through the meter is proportional to the r-f power absorbed.

(c) This basic thermistor bridge circuit has two disadvantages: The sensitivity (microamperes of meter reading per milliwatt of r-f power) varies with temperature, and the METER ZERO SET control has to be adjusted for every measurement because of changes in thermistor bead temperature. The methods of compensating for this effect in the signal generator are described in the following paragraphs.

(2) Compensation for Change in Sensitivity.

(a) The thermistor bridge shown in figure 28-A increases in sensitivity with decrease in temperature. The sensitivity (ohms/watt) of the thermistor remains constant over a broad temperature range, but the bridge sensitivity (microamperes meter reading per milliwatts r-f power) increases with decrease in temperature. As the temperature decreases, the thermistor resistance R_{35} tends to increase, making it necessary to adjust the METER ZERO SET control P_9 to apply a higher voltage across points A and B. Thus the current through meter M caused by a given change in thermistor resistance is greater at a lower temperature because of the higher voltage across A and B.

(b) This variation in sensitivity could be compensated for by increasing the meter resistance as temperature decreases. Since thermistors have this characteristic increase in resistance with decrease in temperature, a disk thermistor (R_{39}) mounted outside the cavity, is placed in series with the meter (fig. 28-B). It is necessary to put resistor R_{38} in series and resistor R_{37} in parallel, with appropriate values, to obtain the correct rate of change of resistance with temperature, so that the sensitivity of the bridge remains constant over the required temperature range.

(3) Compensation for Zero Drift. To decrease the number of times resetting of the METER ZERO SET control becomes necessary, an automatic method of increasing the current through the bead thermistor (R_{35}) with decrease in temperature is required. If a disk thermistor whose resistance increases with decreasing temperature were mounted outside the cavity and connected in parallel with the bridge, more current would flow through the bridge at lower temperature because the ratio of the resistance of the shunting disk thermistor to the resistance of the bridge (across points A and B) is greater at lower temperature (fig. 28-C). Adjusting this compensation to cover the required temperature range, the disk thermistor (R_{40}) is combined in a network with resistors R_{41} , R_{42} , and R_{43} .

(4) Complete Thermistor Bridge Circuit. The thermistor bridge used in the signal generator has both the sensitivity compensation and zero-drift compensation. The compensating networks are designed for an average bead thermistor so that compensation is correct

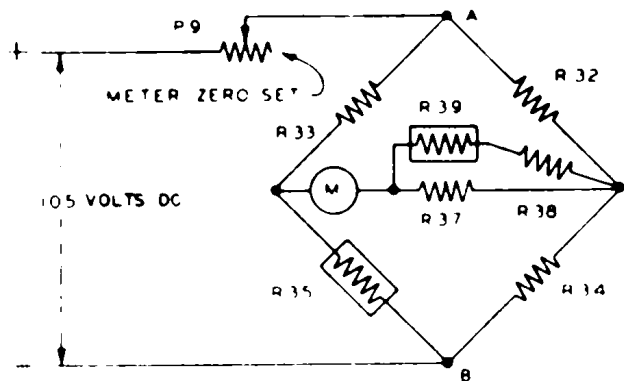
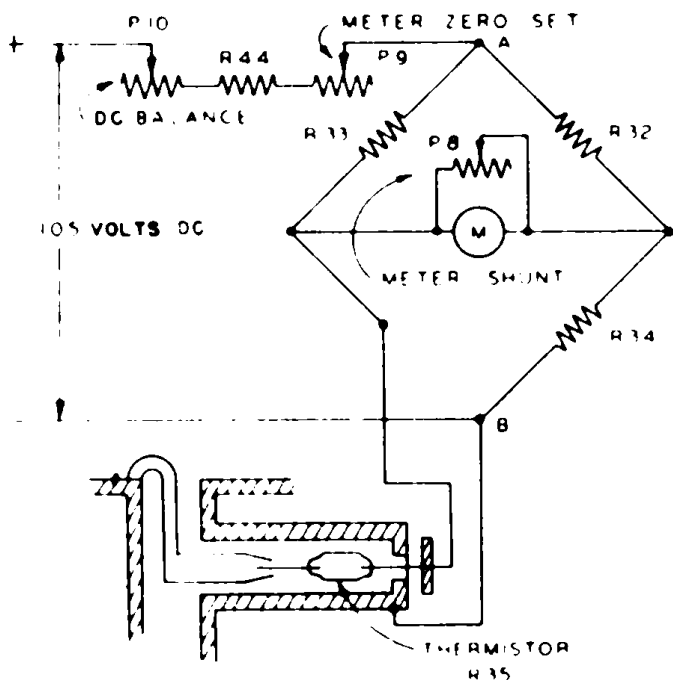

B) SENSITIVITY COMPENSATION

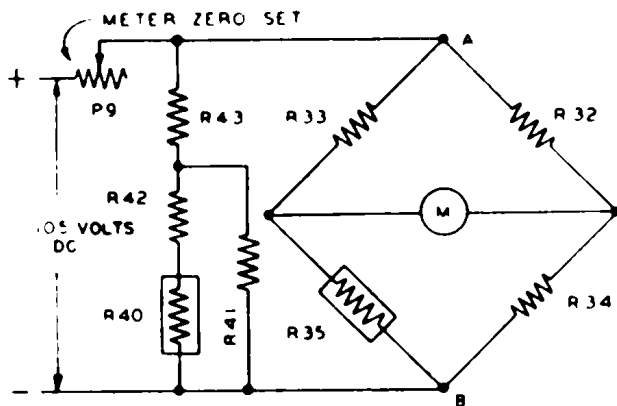

(C) ZERO DRIFT COMPENSATION

TL49880

Figure 28. Thermistor bridge circuit.

at 0°C and 60°C. Between these points, compensation is quite satisfactory. However, because of the variation of electrical characteristics of bead thermistors, the METER ZERO SET control cannot be entirely eliminated. Potentiometer P10 is added in series with P9 for factory adjustment of voltage applied to the thermistor bridge.

i. Attenuator. The power from the type 446B or 2C40 tube is coupled through a coupling loop (J) and coaxial line to the junction of the thermistor mount and attenuator (fig. 16). Part of the energy goes into the coaxial line to the thermistor bead (Y) and part is coupled by coupling loop (T) into a waveguide beyond the cut-off-section. The amount of attenuation is proportional to the length of the waveguide beyond cut-off and is adjustable by the R.F. ATTENUATOR control. The transition back to coaxial line is made by a coupling loop (Q) backed by a resistive disk (R) which consists of a carbon-coated bakelite disk for terminating the coaxial line (X) with its characteristic impedance. An r-f bypass capacitor (V) and polyiron choke (U) are mounted in the thermistor housing for r-f filtering purposes. The d-c path from the thermistor to ground is completed through the coupling loop (T).

j. Power Supply (fig. 29).

(1) The power supply uses a transformer T2, one SU4G full-wave rectifier tube (V8), one OD3 VR-150 voltage regulator tube (V6), and one OC3 VR-105 voltage regulator tube (V7). Inductor L3 and capacitors C19 and C20 form an inductance-capacitance filter with capacitor input.

(2) The voltage for the r-f oscillator tube (V9) is taken from the R.F. OSC OUTPUT potentiometer (P7) in the voltage divider consisting of R25, P7, and R26 across the positive filter terminal and ground.

(3) The peak voltage for the delay multivibrator is regulated by a OD3 VR-IS0 glow discharge voltage regulator (V6). The current of this voltage regulator tube is limited by resistors R27 and R28. Additional filtering is provided by C21 and C25.

(4) The voltage for the wattmeter bridge is regulated by a OC3 VR-105 glow discharge voltage regulator (V7). Resistor R45 is the current limiting resistor for this regulator tube.

(5) Negative bias voltage is obtained from the d-c voltage drop in the filter choke L3 and the potentiometer P6.

35. FUNCTIONING OF SIGNAL GENERATOR CIRCUITS (fig. 29).

The individual circuits described above may be selected in various combinations by means of the selector switch. The performance of these circuits as combined in the different positions of the selector switch is described below.

a. Calibration (CALIB).

(1) The power output of the signal generator is standardized with the selector switch in the CALIB position. Under these conditions, the blocking oscillator puts out sharp negative pulses at a repetition rate of approximately 650 cycles per second (approximately 800 cycles for the TS-155A UP). This frequency is determined by the time constant of R3, R21, and C17. The pulses are then passed on by the buffer cathode follower tube V5B.

(2) The pulse from the buffer cathode follower is fed to the grid of tube VIB, where it is amplified, and triggers the pulse multivibrator. When triggered, the pulse multivibrator produces a relatively long rectangular pulse, which length (about 50 microseconds) is preset at the factory by adjustment of potentiometer P3. The rectangular pulse is passed on to the pulse modulator tube V4.

(3) Oscillator tube (V9) is pulsed into oscillation by the rectangular pulse applied to the oscillator cathode from pulse modulator tube V4. The width of these pulses is greater than that obtainable with the selector switch in either INT TRIG or EXT TRIG position so that the average power is sufficient to obtain full-scale reading of the power monitor meter for standardizing the peak power output. The power output of the oscillator is controlled by the R.F. OSC OUTPUT control (P7) which varies the plate voltage of the oscillator tube V9.

(4) The standardization in the CALIB position is made by setting the R.F. OSC OUTPUT control so that the power monitor meter reads 200 (full-scale). The instrument will then furnish the proper peak power at the R.F. jack, when operated on INT TRIG or EXT TRIG,

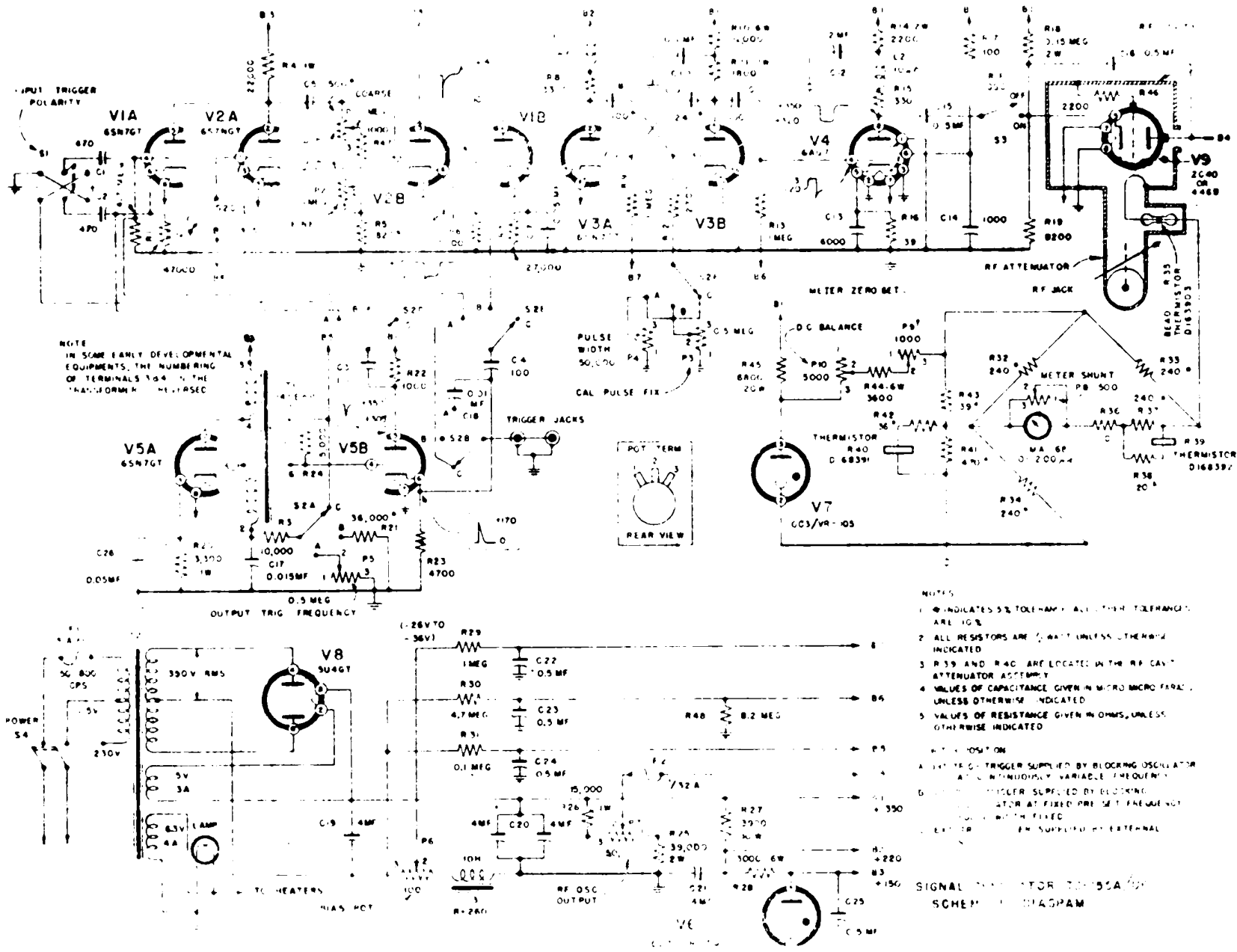

Figure 29. Signal Generator TS-155A/UP, complete schematic diagram.

so that the R.F. ATTENUATOR dial will be directly calibrated in -dbm, as shown in table III.

b. Internal Synchronization (INT TRIG).

When the selector switch is on INT TRIG, the blocking oscillator tube (V5A) puts out a positive trigger at a repetition rate which can be varied between 120 and 2,000 cps by means of the OUTPUT TRIG FREQUENCY control (P5). The pulses are passed on by the buffer cathode-follower tube (V5B). This produces a negative pulse at the plate (pin 5) and a positive pulse at the cathode (pin 6) of V5B. The negative pulse and positive pulse are then applied simultaneously to the cathode (pin 6) and grid (pin 4), respectively, of tube V1A, which in turn triggers delay multivibrator tube V2. This trigger sets off the entire process described in the analysis of the circuit and results in an r-f pulse of variable width and variable delay with respect to the trigger. The positive trigger from the cathode (pin 6) of the buffer cathode-follower (V5B) is also available at the TRIGGER jacks.

c. External Synchronization (EXT TRIG).

When the selector switch is on EXT TRIG, the signal generator may be triggered with either a positive or negative trigger. The INPUT TRIGGER switch must be in the proper position: + (positive) and -(negative) for a positive and negative trigger, respectively. The external trigger is coupled in through one of the TRIGGER jacks. Since the two TRIGGER jacks are connected in parallel, an external trigger coupled into one of the jacks is available at the other jack for simultaneously triggering other equipment. The trigger is fed into the trigger inverter which applies a pulse of the correct polarity to the delay multivibrator V2, setting off the entire process described in the analysis of the circuit, and results in an r-f pulse of variable width and variable delay with respect to the trigger.

36. FUNCTIONING OF SIGNAL GENERATOR IN TESTING RADAR SYSTEMS.

The signal generator is used to measure the relative performance of radar sets so that a decrease in performance can be detected and remedied. The relationship between the performance as measured by signal generator TS-155/UP and optimum performance is described in part two. The fundamentals of the method of testing radar sets with Signal Generator TS-155/UP are illustrated in figures 4 and 5. The radar set and the signal generator are synchronized with the

trigger from either one or the other as described in part two, paragraph 14. The signal generator is standardized as described in paragraph 35a above.

a. Measuring Transmitter Power Output.

(1) Pulses of energy from the radar transmitter are radiated by the radar antenna through space, as shown in figure 30. When a dipole antenna is used, part of the energy is picked up by the dipole antenna and transmitted through the cable and signal generator attenuator to the power monitor of the signal generator. When a directional coupler is installed in the radar r-f line at point L of figure 30, a cable can be connected from the directional coupler to the R.F. jack of the signal generator. In this case a fraction of the radar transmitter energy is coupled through the directional coupler, cable, and r-f attenuator to the power monitor of the signal generator. When the signal generator controls are adjusted as outlined in part two, the power monitor meter reads the average power at the R.F. jack directly in milliwatts.

(2) It is not usually necessary to convert transmitter power, as measured at the R.F. jack of the signal generator, to actual power in the radar transmitter line back of the antenna. Once a radar set has been checked while operating normally, it is the knowledge of changes in performance that is of value to the radar operator. Changes in radar performance, as measured by the signal generator, indicate actual changes only if the space loss is kept constant from day to day by maintaining the same distance and relative position between radar antenna and signal generator dipole. To convert to average power behind the radar antenna (point L in figure 30), it is necessary to know the cable loss, dipole antenna gain, space loss, and the radar antenna gain. Alternately, if a directional coupler is installed in the radar transmission line, only the cable loss and the attenuation constant of the directional coupler need be known. The measurement of cable loss, dipole antenna gain, space loss, and radar antenna gain is difficult and requires special equipment not supplied with this signal generator.

b. Measuring Receiver Sensitivity.

(1) The signal generator is used to generate a signal of the frequency of the radar transmitter for testing the receiver sensitivity.

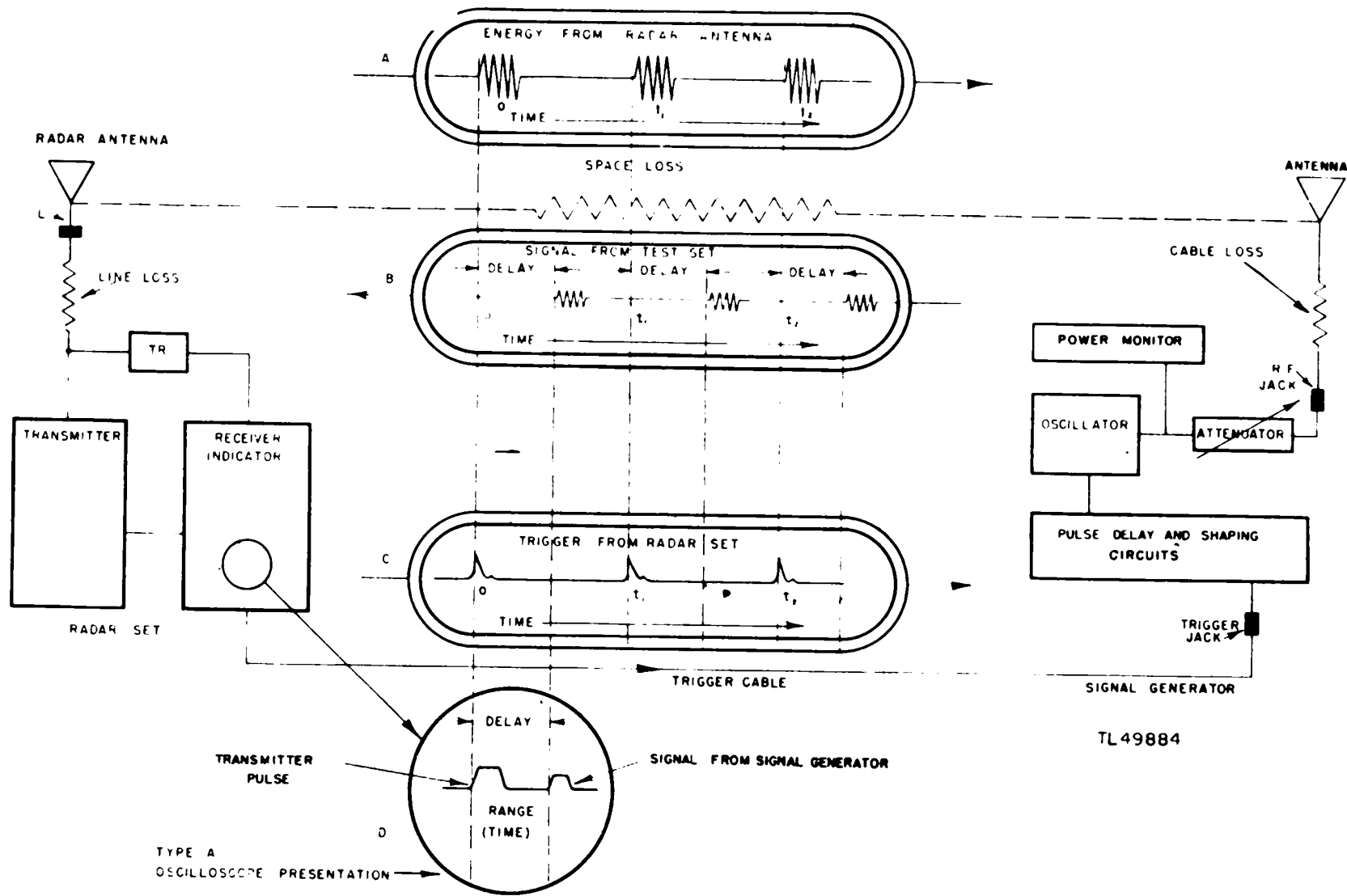

Figure 30. Signal Generator TS-155/UP, operation with radar set.

After measuring transmitter power output, the cavity is adjusted to the transmitter frequency by tuning to a dip in the power monitor meter reading. The R.F. TUNING dial is then corrected by a constant amount (turn dial counterclockwise three divisions) to compensate for the difference between the "cold" resonant frequency of the oscillator cavity and the resonant frequency of the cavity with the type 446B or 2C40 tube oscillating. The timing of the signal generator pulses is controlled by the trigger from the radar set. The time of delay of the signal generator pulse, after the trigger front the radar set, is controlled by the delay circuits of the signal generator. The signal from the signal generator presented on various types of oscilloscopes is shown in figure 31.

(2) The signal observed on the radar indicator should be adjusted below saturation by means of the signal generator R.F. ATTENUATOR. The power output of the signal generator is standardized by first adjusting the oscillator for full scale reading of the power monitor meter, with the selector switch in CALIB position as described in part two. The selector switch is then returned to INT TRIG or EXT TRIG, depending upon the synchronization used. The relative receiver sensitivity is measured by turning the R.F. ATTENUATOR dial until the test signal produced by the signal generator on the radar indicator is just visible in the noise. The R.F. Attenuator dial reading gives the peak power at the R.F. jack (in -dbm) of the smallest signal observable with the radar receiver.

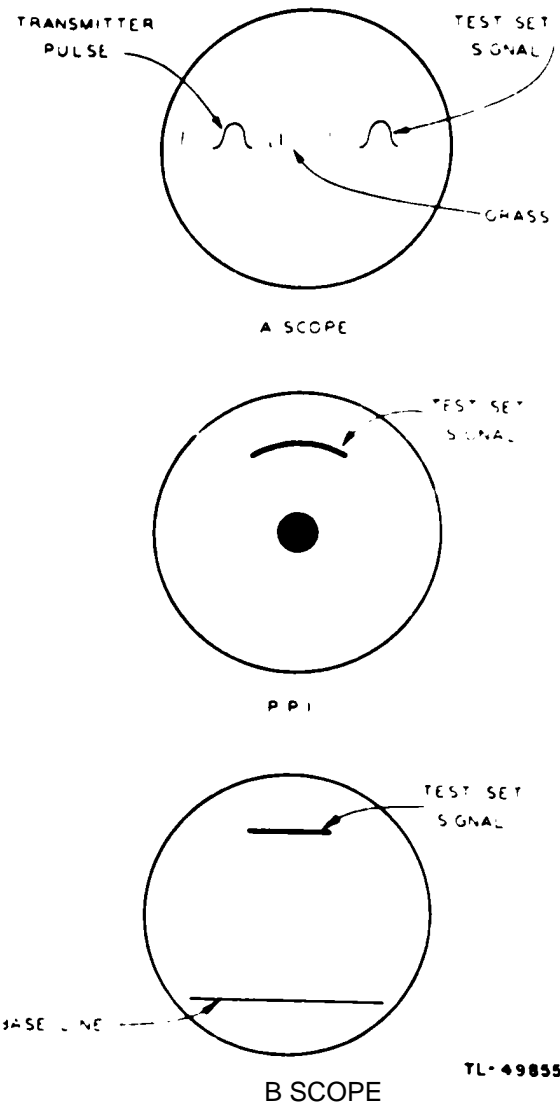

Figure 31. Test set signal on A-, PPI, and B scopes.

SECTION X - TROUBLE-SHOOTING PROCEDURES

37. PRINCIPAL PARTS OF TEST SET.

The principal parts of the instrument that may require servicing are:

- a. Cavity.
- b. Thermistor bridge monitoring system.
- c. Attenuator.

- d. Pulsing and internal trigger circuits.
- e. Power supply.

38. ACCESS TO PARTS FOR MAINTENANCE.

- a. The chassis and front panel may be removed from the cabinet by loosening the captive screws on the front panel (fig. 6).

b. When the chassis has been removed, all items such as tubes, pilot lamp, fuse, etc., requiring easy replacement are readily accessible, with the exception of type 446B or 2C40 tube which is located within the cavity, and the bead thermistor which is located within the thermistor housing. All circuit components such as resistors, capacitors, etc., may be easily reached and replaced if necessary. Most of these are mounted on terminal strips located in the bottom of the chassis (fig. 11).

39. PULSING AND INTERNAL TRIGGER CIRCUITS.

a. *General* The theoretical discussion of these circuits given in section IX should be read before investigating the performance of these circuits. Figures 10, 11, and 29 are helpful in locating parts and location of trouble. Paragraph 42 contains voltage and resistance charts. The waveforms normally found throughout the system are shown in figure 23. In general, if the correct waveform is seen at the input of any stage, but an improper one at the output of the same stage, a replacement tube should be tried and the plate voltage checked before attempting further tests of the circuit.

b. *Pulsing Circuit* The pulsing circuit should be checked for each of the three positions of the selector switch

(1) CALIB position.

(a) The circuit may be checked by connecting the trigger input of a synchroscope to a TRIGGER jack on the signal generator. The synchroscope signal input should be connected between the cathode of type 446B tube and ground. Also, connect a jumper from the high side of C18 to the central terminal of the TRIGGER jacks. Essentially, a square pulse of fixed width and repetition rate should be observed. If a synchroscope is not available, a rough check may be made with an oscilloscope of high sweep speed by connecting it in the same manner. A recurrence frequency of approximately 650 cycles is required (approximately 800 cycles for TS-SS5A,UP).

(b) The pulse amplitude should be about 30 volts, and the pulse should start (on the synchroscope screen) at the beginning of the sweep. If the pulse waveform is distorted or does not appear, the

synchroscope should be used to observe the waveform at the grid of V4 (pin 4), at the plate of tube V31r: (pin 5), and at the plate of V1B (pin 2).

(c) If no pulse is found at the plate of V1B (pin 2), a check should be made at the grid (pin 1) of this tube. At this grid a positive trigger from the cathode of V5B (pin 6) should be observed. If it is not, the blocking oscillator tube, V5A is probably not functioning and should be checked.

(2) INT TRIG Position.

(a) In this type of operation, a positive trigger should be available at either of the TRIGGER jacks. The repetition rate of this trigger can be varied by means of the OUTPUT TRIG FREQUENCY OUTPUT TRIG FREQUENCY control.

(b) When a synchroscope is synchronized with this trigger, synchronization is indicated by varying brightness of the sweep trace as the OUTPUT TRIG FREQUENCY control is varied. (Note that some synchrosopes cannot be triggered if the repetition rate is too low, about 400 cycles.)

(c) With the R.F. OSC switch ON, a short pulse (whose width is variable by means of the PULSE WIDTH control) should be observed on the cathode and on the plate of type 446B or 2C40 tube. If the pulse is distorted but its delay can be varied by the PULSE DELAY control, look for trouble, only as far back in the circuit as the first plate (pin 2) of V3A.

(d) If no pulse appears or if the delay cannot be controlled by the PULSE DELAY control, the waveforms at the plates (pins 2 and 5) and the cathode either pin 3 or pin 6) of tube V2 should be checked and compared with the corresponding forms in figure 23.

(e) The trailing edges (right-hand side on synchroscope screen) of the pulses found on the cathodes (pins 3 or 6) should be movable by means of the PULSE DELAY control. If these waveforms do not appear, or if they are quite distorted, a tube check and a plate voltage check should be made on this stage.

(3) EXT TRIG Position The INPUT TRIGGER polarity switch is set to correspond to the polarity of the

external trigger fed into one of the TRIGGER jacks. The operation of the circuit is very similar to that on INT TRIG position except that switch S1 permits use of triggers of either polarity, and that tube V5A does not oscillate. It is very important that all the spring fingers in the resonant cavity make good contact, because even a few spring fingers that do not make good contact can prevent the tube from oscillating. Most troubles with the r-f oscillator are caused by poor contacts or defective tubes. See paragraph 43b for information on how to disassemble cavity.

c. Power Supply. The power supply is a conventional full-wave rectifier system with various voltage outputs filtered by individual R-C filters. Lack of or incorrect d-c voltage at any point in the signal generator can often be traced to the power supply, the repair of which usually consists of replacing defective tubes or burned-out resistors or capacitors.

40. THERMISTOR BRIDGE MONITORING SYSTEM.

a. Set the selector switch to CALIB and turn on the signal generator. It should be possible to zero-set the monitoring meter by means of the METER ZERO SET control. If this is not possible, the voltage across the thermistor bridge, between ground and the junction of R32 and R34 should be checked. This voltage should read between 1.4 volts and 1.5 volts. The variable resistor (P10) should be adjusted until it is possible to zero-set the monitoring meter with METER ZERO SET control on the front panel.

b. If it is still impossible to zero-set the monitoring meter, the voltage at the anode of tube V7 should be measured. This voltage should be close to 105 volts. A continuity check should also be made on the thermistor bridge circuit. In particular, the bead thermistor should be checked for continuity.

c. The resistance of the bead thermistor will vary with the amount of current flowing through the bead, and hence this indication is affected by the type of ohmmeter that is used. With the average ohmmeter, the resistance should measure between 500 and 1,500

ohms. A more exact specification is that the resistance at 23.9°C, with 25 milliamperes of direct current flowing through the bead, should lie between 33 and 47 ohms. In general, it may be said that if the bead has continuity, it will operate in the monitoring bridge circuit.

d. The resistance of the bead thermistor can be measured by disconnecting the lead on top of the thermistor housing and placing the ohmmeter leads between the frame of the chassis and the threaded screw at the top of the upper section of the thermistor housing. For information on how to replace the thermistors, see paragraph 43c.

41. ATTENUATOR CABLE.

If the monitoring meter indicates that the cavity is oscillating and is developing sufficient power but the power at the ANT jack is inadequate, the trouble probably lies between the thermistor connecting link and the connector for the attenuator cable. A check should be made of the attenuator cable. This unit receives considerable flexing while the instrument is in use. It is therefore reasonable to expect that this part may fail. To check this, disconnect the attenuator cable and measure the power at the output of the attenuator piston. If the power is of the correct magnitude at this point, replace the attenuator cable with a new one.

42. TEST ANALYSIS DATA.

a. General. The following data was obtained with a standard 20,000-ohms-per-volt analyzer. Although the measurements indicate the values to be expected, each signal generator differs to some extent. Therefore, it is recommended that similar charts be prepared by the using unit for each signal generator that is operating properly.

b. Voltage Chart. The following voltages were measured between the tube socket pin indicated and ground, using a 20,000-ohms-per-volt meter. No external trigger voltage was used. The R.F. OSC switch was off.

VOLTAGE CHART

Tube	PIN								Selector switch
	1	2	3	4	5	6	7	8	
V ₁	0	215	12	0 0 0 to - 1.7 ^a	140	7.6 7.6 1.7 to 6.4 ^a	0	6ac	EXT CALIB INT
V ₂	0 -36 0	140	11.7 11.7 3.3 to 13 ^c	2.3 to - 6.8 ^b 0.9 to 5.3 ^c -70.7 to 7.5 ^b	145	11.7 11.7 3.3 to 13 ^c	0	6ac	EXT CALIB INT
V ₃	-14	215	0	0 -0.5 0	150	0	0	6ac	EXT CALIB INT
V ₄	0	0	0	-7.5	0 0.15 0	352	6ac	350	EXT CALIB INT
V ₅	-39	350	0 10 0 to 31 ^a	36	350	0 0.6 0 to 2 ^a	0	6ac	EXT CALIB INT
V ₆		0			145				
V ₇		0			100				
V ₈ V ₉ ^e		350 ^d		400ac 44dc	37	400ac 44dc	6ac	350 ^d	

^a Varies with **OUTPUT TRIG FREQUENCY** control.

^b Varies with **PULSE DELAY** and **OUTPUT TRIG FREQUENCY** control.

^c Varies with **PULSE DELAY** control.

^d 5 volts ac between pins 2 and 8.

^e Viewed from back of chassis, pin 5 is left terminal and pin 7 the right.

At the plate pin at the front of the cavity, under side of chassis, the voltage varies with the R.F. **OSC OUTPUT** control between 125 and 285 volts dc.

c. Resistance chart. The following resistances were measured from the tube socket pins indicated to ground. A 20,000-ohms-per-volt meter was

used. No power was supplied to the signal generator. The R.F. OSC switch was off.

RESISTANCE CHART

Tube	PIN								Selector switch
	1	2	3	4	5	6	7	8	
V ₁	10,000	16,500	26,000	5 meg	40,000	0.45 meg	0	0	
V ₂	0 0.1 meg 0	40,000	0	1,800 ohms to 1.1 meg ^b	17,000	0	0	0	EXT CALIB INT
V ₃	6 meg	17,500	0	2,700 55,000 ^d 0.24 meg 2,700 to 55,000 ^d					EXT CALIB INT
V ₄	0	0	0	3.75 meg	40	10,000	0	13,000	
V ₅	0.12 meg 45,000 11,000 to 511,000 ^a	10,000	3,500	0.1 meg	11,000	4,500	0	0	EXT CALIB INT
V ₆		0			17,000				
V ₇		0			4,500				
V ₈		10,000		500		500		10,000	
V ₉ ^c					8,000		0		

^a Varies with **OUTPUT TRIG FREQUENCY** control.

^b Varies with **PULSE DELAY** control.

^c Resistance at plate of V₉, is 27,500 ohms. Plate is on front of cavity on under side of chassis.

^d Varies with **PULSE WIDTH** control.

43. MECHANICAL REPAIRS.

a. Structural Difference in "PR" and "AO" Cavities

(1) As previously mentioned Signal Generator TS-155/UP uses the "AO" cavity while Signal Generator TS-155A/UP uses the "PR" cavity. For servicing purposes the only difference between these two types of cavities is:

(a) The stop mechanism for the tuning dial shaft.

(b) The location of the plunger locking screw.

(c) The means for securing the tail piece to the cavity.

(2) In the "PR" type of cavity (fig. 3) the stop mechanism consists of a small rectangular bar which fits on the tuning dial shaft and is clamped to it by a lock screw. The tuning dial is thus restricted to a 270° rotation by the rectangular bar striking against the stop. Refer to section IX, paragraph 32a(8) and (9).

(3) In the "AO" type of cavity (fig. 3) the stop mechanism consists of a pin which is mounted in the tuning dial shaft and an adjustable washer, through which the shaft passes.

This is mounted on the front face of the cavity and secured to it by means of a lock screw. However, when the lock screw is loosened, the tuning dial shaft is free to rotate about 1/2 revolutions.

NOTE: In the "PR" type of cavity the stop mechanism is accessible at the rear of the front panel and the tuning dial need not be removed for this adjustment. In the "AO" type of cavity the tuning dial must be removed and access to the stop mechanism is obtained through a hole in the front panel.

(4) In the "PR" type of cavity the plunger locking screw is located under a removable cap which is opposite the plunger screwdriver adjustment (fig. 3).

(5) In the "AO" type of cavity the plunger locking screw is located below the plunger adjusting screw, (fig. 3).

(6) In the "PR" type of cavity the tail piece may be removed after loosening the tail piece clamp screw shown.

(7) In the "AO" type of cavity the tail piece may be removed after removing the six screws that hold the tail piece in the cavity.

b. Replacing a Type 446B or 2C40 Tube (fig. 15).

(1) Turn the POWER switch and R.F.

OSC switch off and disconnect the power cord from the main source.

(2) Remove the grid leak housing from the cavity.

CAUTION: The grid leak housing which contains the grid leak must be removed before the tail piece. It must not be replaced until the tail piece has been permanently reassembled in the cavity; otherwise damage may result to the grid cylinder assembly and to the grid leak.

(3) Turn the tuning dial fully counterclockwise. This moves the plate cap fingers to a position close to the end of the plate cap of the tube and minimizes the possibility of breaking the tube when it is removed.

(4) Remove the tail piece from the cavity. Follow the instructions in subparagraphs a(6) and (7) above.

(5) Withdraw the tail piece by rotating it slightly and pulling backwards.

(6) Remove the grid cylinder sleeve assembly from the tube, being careful not to break the grid ring of the tube to which this assembly is attached.

(7) Insert a new tube in socket of tail piece.

(8) Install the grid cylinder sleeve assembly on the grid ring of the tube, taking care to prevent breaking the tube. The length of this assembly should not be changed at this time.

NOTE: Before installing the grid cylinder sleeve assembly and the type 446B or 2C40 tube, they should be thoroughly cleaned with Solvent, Dry-cleaning, Federal Specification P-S-661a. Care should be taken not to get finger marks on either.

(9) Loosen the adjusting screw in the rear of the tail piece to permit slight freedom of the tube socket. Turn the tuning dial fully clockwise, then back off approximately ten dial divisions.

(10) Insert the tail piece fully in the cavity using care that the plate cap is entering the plate cap fingers without undue strain. This operation can be facilitated by moving the adjusting screw about as the tail piece is inserted into the cavity. Turn the tuning dial to make sure there is no binding. Tighten the adjusting screw nut.

(11) Tighten the tail piece in the cavity. In the "PR" cavity, this is accomplished by tightening the screw in the tail piece clamp. In the "AO" cavity, insert the six securing screws and tighten them progressively to insure that the tail piece is "bottoming" properly. This must be done carefully to prevent distorting the cavity and to insure complete electrical shielding of the end of the cavity.

(12) Install the grid leak housing in the cavity.

(13) The plate tuning shaft must now be adjusted to the correct operating position unless the new tube has exactly the same height as the replaced tube. If not, the tuning dial setscrews must be loosened and the dial removed.

(14) Loosen the lock screw of the stop. Refer to subparagraph a above and figure 3 for differences in the two types of cavities.

(15) Turn the tuning dial shaft clockwise until the plate cap fingers "bottom" against the plate cap disk of the tube. This "bottoming" can be felt when the shaft is rotated with the fingers (16) With the tuning dial shaft in a full clockwise position, set the stop so that the tuning dial shaft cannot be moved clockwise beyond this point. Tighten the lock screw.

(17) Replace the tuning dial, if it was removed to adjust a type "AO" cavity. In either case, adjust the tuning dial to read zero and secure it with its setscrews. Test the mechanical operation of the cavity for binding over the tuning range of zero to 100. If necessary, loosen the tail piece adjusting screw and turn the tuning dial from zero to 100 several times. Then tighten the tail piece adjusting screw at the point until the binding, if any remains, is at a minimum.

(18) If the tuning dial occupies a new position on its shaft, it may be necessary to remove any burr on the surface of this shaft caused by the dial setscrews.

c. Replacing the Thermistors (fig. 15).

(1) Two type of thermistors are required and used in the thermistor bridge monitoring circuit. These are the bead thermistor and the two disk thermistors.

CAUTION: The thermistors rarely need replacing and should be replaced only when proved defective. The bead thermistor, particularly its mounting, is quite delicate.

(2) The bead thermistor is a small glass unit about 3/8, inch long and 1/8 inch in diameter with short lengths of wire projecting from each end, which act as terminals.

(3) The bead thermistor may be removed from the thermistor housing by loosening the securing nut on top of the thermistor housing and removing the upper section of the thermistor housing. The wire lead from the bead thermistor may now be seen projecting through the spring fingers of the brass disk. With a pair of longnose pliers or tweezers, carefully lift this small

projecting wire. This will extract the bead thermistor and brass disk.

(4) In replacing the bead thermistor, one of the projecting leads should be cut to the same length as the lower lead of the replaced thermistor which had been inserted into the slotted end of the tapered brass transmission rod. The other lead on the new bead thermistor should not be cut at this time. Leaving this top lead with its original length will facilitate the insertion of the bead thermistor into the slotted end of the brass rod. It will also provide an easy means of replacing the brass disk which was removed with the old bead thermistor. The end of the bead thermistor from which the wire was cut should be lowered into the thermistor housing and pushed into the slotted end of the tapered brass rod. After the brass disk is pushed down over the projecting lead from the bead thermistor and seated on the base of the opening at the top of the thermistor housing, the wire lead may be cut off about 1/16 inch above the top of the spring fingers on the brass disk.

(5) Replace the upper section of the thermistor housing and tighten the securing nut.

(6) The disk thermistors may be removed by removing their securing screws. Note that one of the disk thermistors is insulated from ground by a thin mica sheet.

(7) If the bead thermistor is replaced, the following resetting procedure will be necessary:

(a) Set R.F. ATTENUATOR dial at reference mark for measuring input power.

(b) Set R.F. TUNING dial at zero or 100, whichever is further from frequency of power source to be used.

(c) Turn POWER switch ON.

(d) R.F. OSC switch should be off.

(e) Set meter at zero with METER ZERO SET.

(f) Feed 200 milliwatts of power into R.F. jack.

(g) Adjust meter shunt (P8) until meter reads exactly 200.

(8) The above procedure will reset signal generator for operation without need for further calibration. If the meter shunt (P8) will not give sufficient adjustment, the signal generator will have to be recalibrated.

d. Attenuator.

(1) The attenuators in both types of cavities are very similar structurally. This unit rarely requires servicing although it is conceivable that the contact fingers of the piston may require adjustment or lubrication. This would be indicated by an intermittent contact as the attenuator dial is rotated.

(2) The piston may be removed by removing the limit screw shown in figure 15, after removing the attenuator cable by unscrewing the Type N plug at the end of the attenuator. The piston may then be pulled entirely out of the attenuator tube. Care should be taken to avoid damage to the attenuator loop (Q) and to the contact fingers near it. When the piston is replaced, the calibration reference mark (red line on dial) should line up with the dial indicator when the piston is fully compressed.

CAUTION: Unless a means of standardizing the signal generator is available, the attenuator piston should preferably not be removed. The adjusting screw on the attenuator is set at the factory so that when 200 milliwatts is fed into the ANT jack and the attenuator piston is completely compressed, the monitoring meter gives a full-scale reading. The attenuator loop is clamped in a vertical plane and rides at the top of the attenuator tube. If the relative positions of the parts within the attenuator are changed, the calibration of the attenuator dial may be destroyed.

44. ADJUSTMENTS

a. Adjustment of Electrical Constants of the Cavity for Optimum Operation with a Type 446B or 2C40 Tube

(1) The type 446B tubes vary considerably in their electrical characteristics and it may be necessary to adjust the grid cylinder sleeve assembly and the plunger for optimum operation with a replacement tube.

The normal length of the grid cylinder sleeve assembly (fig. 15) is 1-3/4 inches.

(2) The depression in the split grid cylinder must fit into one of the holes in the main grid cylinder and the fingers of the main grid cylinder must make good contact with the grid ring of the tube.

(3) To check for frequency coverage and for optimum oscillating conditions, proceed as follows. (It is assumed that the type 446B tube is in the cavity, the grid cylinder sleeve assembly is adjusted to its normal length, the grid leak is in position, and that the lead from the grid leak is contacting the grid cylinder sleeve assembly.)

(a) Loosen the plunger locking screw. Refer to paragraph 43a(4) and (5) and to figure 3.

(b) Connect the signal generator to the power source and turn the POWER switch to ON, and the R.F. OSC switch to OFF.

(c) Wait several minutes until the instrument has warmed.

(d) Set the INT TRIG CALIB EXT TRIG selector switch to CALIB.

(e) Balance the monitoring meter reading to zero by adjusting the METER ZERO SET control (fig. 6).

(f) Throw the R.F. OSC switch to the ON position.

(g) Rotate the R.F. OSC OUTPUT potentiometer until the monitoring meter reads approximately 160.

(h) Turn the R.F. TUNING dial to read 45.

(i) Remove the cap nut and by means of the screwdriver adjustment, adjust the plunger slowly backward and forward until the monitoring meter reading is at maximum.

(j) Measure the frequency, or the wavelength, of the oscillator with the tuning dial set at 45 (subpar. b. below). If the frequency, or the wavelength, is within the limits of the following table, proceed directly to step n.

TABLE IV

CAVITY ADJUSTMENT DATA FOR OPTIMUM OPERATION OF TS-155/UP

	Normal limits with tuning dial reading of 45
Frequency in megacycles.....	2,795 to 2,810
Wavelength in centimeters.....	10.69 to 10.74
Length of grid cylinder.....	1-3/4" ± 3/16"

(k) If the frequency is greater than the values specified in the table IV, lengthen the grid cylinder sleeve assembly by one indentation at a time.

(l) If the frequency is lower, shorten the assembly by one indentation at a time.

NOTE: To adjust the grid cylinder sleeve assembly review the pertinent portions of the instructions for replacing a type 446B tube, paragraph 43b.

(m) If, after changing the length of the grid cylinder sleeve assembly within the limits given in table IV and repeating the plunger adjustment (paragraph i above) the frequency of the oscillator is not within 7 mc but is very close to it, the frequency may be brought within limits by a very slight adjustment of the plunger. It must be noted that only a slight adjustment of the plunger is tolerable; otherwise the power output of the cavity may be impaired. The frequency at 0 and 100 setting of R.F. TUNING dial should be checked to determine that the entire band from 2,700 to 2,900 mc is covered.

(n) Turn the tuning dial slowly from 5 to 95, while watching the monitoring meter. With the R.F. OSC OUTPUT control on full, the tube should oscillate and give at least a full-scale monitoring meter reading over this range.

(o) Tighten the plunger locking screw and replace the cap nut.

b Frequency Adjustment with Wavemeter Test Set TS-117/GP.

(1) If Wavemeter Test Set TS-117/GP is available, connect the R.F. jack of the signal generator to the TUNE TO DIP jack on the wavemeter. Connect a conventional cathode-ray oscilloscope to the VIDEO jack of the wavemeter and TRIGGER jack of the signal generator to give a visual indication of the frequency adjustment (fig.30). The XTAL CURRENT meter on the wavemeter is not sensitive enough, and the oscilloscope must be used. Using the waveform on the oscilloscope as the indicator, adjust the cavity frequency by means of the grid cylinder or the coarse frequency adjustment (plate fingers) until the desired frequency range (2,700 to 2,900 mc) is covered by the signal generator and the monitoring meter can be made to read at least full-scale at all frequencies in the range. A decrease in the amplitude of the pulse waveform on the oscilloscope signifies that the wave meter is tuned to the signal generator frequency when the r-f is fed to the TUNE TO DIP jack of Wavemeter Test Set TS-117/GP. When the r-f from the signal generator is fed to the TUNE TO PEAK jack, an increase in waveform amplitude results when the wavemeter frequency and signal generator frequency coincide. For detailed operation of the wavemeter refer to TM 11-2538, Wavemeter Test Set TS117/GP.

(2) A calibration curve for the R.F. TUNING dial may be made using the wavemeter to determine the frequency at different settings of the R.F. TUNING dial on the signal generator.

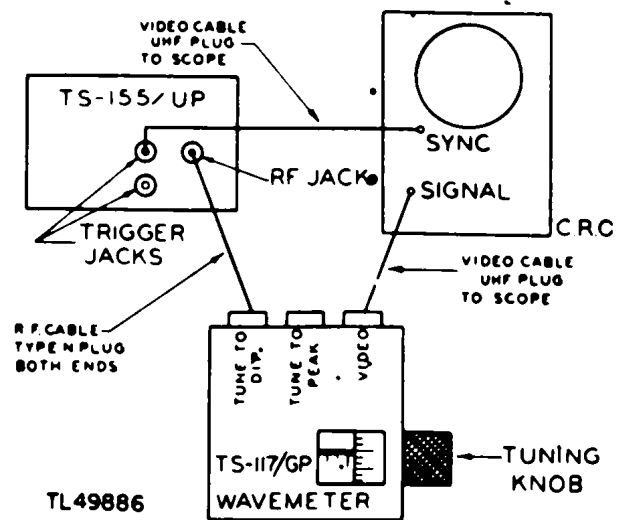

Figure 32. Calibration of Signal Generator TS-15 with Wavemeter Test Set TS-117/GP.

The curve obtained by plotting the dial settings against frequency will give a relatively accurate calibration of the signal generator. Replacement of the oscillator tube or changes in the variables of the cavity will necessitate recalibration of the generator.

NOTE: Since the TUNE TO PEAK jack provides sharper tuning than the TUNE TO DIP jack, using the TUNE TO DI jack to make a rough frequency

adjustment, then transfer to the TUNE TO PEAK jack for the fine adjustment

(3) It may be necessary to produce continuous oscillation for accurate adjustment with Wavemeter Test Set TS117/GP. Continuous oscillation of the r-f oscillator may be obtained by grounding the cathode of the oscillator tube (left-hand terminal on rear of cavity, viewed from rear of signal generator) and by inserting a 10,000-ohm resistor in parallel with R26.

APPENDIX
45. MAINTENANCE PARTS LIST FOR SIGNAL GENERATORS TS-155/UP AND TS-155A/UP

Ref symbol	Signal Corps Stock No.	Name of part and description
C-1 C-2	3K2047111	CAPACITOR, fixed; mica; 470 mmf \pm 10%; 500 vdcw; 11/16" lg x 7/16" wd x 5/32" thk; AWS type #CM20A-471K; (low-loss case; 2 wire leads 1 1/2" lg).
C-3	3K2010111	CAPACITOR, fixed; mica; 100 mmf \pm 10%; 500 vdcw; 11/16" lg x 7/16" wd x 5/32" thk AWS type #CM20A-101K; (low-loss case; 2 wire leads 1 1/2" lg).
C-4 C-11 C-5	3K3015212	CAPACITOR, fixed; mica; 1,500 mmf \pm 10%; 500 vdcw; 3/4" lg x 3/4" wd x 1/4" thk AWS type #CM30A152K; (low-loss case; 2 wire leads 1 1/4" lg).
C-6	3K2015111	CAPACITOR, fixed; mica; 150 mmf \pm 5%; 500 vdcw; 11/16" lg x 7/16" wd x 5/32" thk AWS type #CM20A-151J; (low-loss case; 2 wire leads 1 1/2" lg).
C-7	3DA50-160	CAPACITOR, fixed; mica; 50,000 mmf \pm 20%; 600 vdcw; 1 3/8" lg x 9/16" diam; Sprague PX-24-A (metal case; 2 wire leads 2 7/8" lg).
C-26 C-8	3K2010112	CAPACITOR, fixed; mica; 100 mmf \pm 5%; 500 vdcw; 11/16" lg x 7/16" wd x 5/32" thk AWS type #CM20A101J; (low-loss case; 2 wire leads 1 1/2" lg).
C-9	3K2024112	CAPACITOR, fixed; mica; 240 mmf \pm 5%; 500 vdcw; 11/16" lg x 7/16" wd x 5/32" thk; AWS type #CM20A-241J; (low-loss case; 2 wire leads 1 1/2" lg).
C-10	3DA100-26.13	CAPACITOR, fixed; paper; 100,000 mmf \pm 20%; 600 vdcw; 1 5/8" lg x 5/8" diam; Sprague PX-24-A (metal case; 2 wire leads 2 7/8" lg).
C-12a C-12b	3DB1.SO1-7	CAPACITOR, fixed; paper; 1 mf \pm 20%; 600 vdcw; 2 1/4" lg x 1-5/16" wd x 5/8" thk, Tobe = OM601; (metal case; hermetically sealed; mineral oil impregnation; 2 insulated solder lug terminals on bottom spaced 1/2" on centers; mtg clamp with 2-6/32" studs).
C-13	3DA6-87	CAPACITOR, fixed; paper; 6,000 mmf \pm 20%; 600 vdcw; 1 1/16" lg x 7/16" diam; Sprague PX-24A (metal case; 2 wire leads 2 7/8" lg).
C-14	3K3010211	CAPACITOR, fixed; mica; 1000 mmf \pm 10%; 500 vdcw; 3/4" lg x 3/4" wd x 1/4" thk; AWS type #CM30A102K; (low-loss case; 2 wire leads 1 1/2" lg).
C-15 C-16	3DA500-186.2	CAPACITOR, fixed; paper; 500,000 mmf \pm 20%; 600 vdcw; 2 1/4" lg x 1 5/16" wd x 5/8" thk, Tobe = OM650; (metal case; hermetically sealed; mineral oil impregnation; 2 insulated solder lug terminals on bottom spaced 1/2" on centers; mounting clamp with 2-3/16" studs).

45. MAINTENANCE PARTS LIST FOR SIGNAL GENERATORS TS-155/UP AND TS-155A/UP (cont.)

Ref symbol	Signal Corps Stock No.	Name of part and description
C-17		CAPACITOR, fixed; paper; 15,000 mmf \pm 10%; 300 vdcw; 1-5/32" lg x 5/8" wd x 1/4" thk; Micamold; (bakelite case; 2 wire leads 1 1/4" lg).
C-18	3DA10-276.1	CAPACITOR, fixed; paper; 10,000 mmf \pm 20%; 600 vdcw; 1 1/16" lg x 7/16" diam; Sprague PX-24-A (metal case; 2 wire leads 2 7/8" lg).
C-19		CAPACITOR, fixed; paper; 4 mf \pm 20%; 600 vdcw; 5" lg x 1 1/2" diam;
C-20a		AWS Type umber C.P. 41B2EF 405 TL: (metal case; mineral oil
C-20b		impregnation; 2 solder lug terminals on bakelite protrusion; 3/4" mtg
C-21		hole).
C-22	3DA500-37.2	CAPACITOR, fixed; paper; 500,000 mmf \pm 20%; 400 vdcw; 1 3/4" lg x
C-23		7/8" wd x 15/16" thk, Solar XDMRW4-.5; (metal case; hermetically
C-24		sealed; mineral oil impregnation; 2 insulated solder lug terminals
C-25		spaced 1" in center; 2 mtg ft holes spaced 2 1/8" on center).
E-1	2Z5952	LAMP, incandescent; 6-8v, 0.15 amp; miniature bayonet base sinble
E-2		cont; Tung-Sol #47.
E-3	2Z682035	BOARD, terminal: 2 fuse clips, Littelfuse # 5048; wax impregnated
E-4		phenolic; 2 5/8" lg x 7/8" wd x 1/8" thk; TRC #833.001; (2 mtg holes
E-5		#22 drill on 3/4" centers; mtg/c for fuse clips 2" apart).
E-6	2Z6820.36	BOARD, terminal: 2 fuse clips, Littelfuse # 5048; wax impregnated
E-7		phenolic; 3 1/4" lg x 7/8" wd x 1/8" thk; TRC #833.002; (2 mtg holes
E-8		#22 drill on 1 1/8" apart; mtg holes for fuse clips 2-9/16" on center).
E-9	2Z9400.3	BOARD, terminal: 2 capacitors; wax impregnated phenolic; 5 7/8" lg x
E-10		3/4" wd x 1/4" thk; TRC #833.003; (3 mtg holes #12 drill in line on 2
E-11		5/8" centers).
E-12	2Z9410.102	BOARD, terminal: 19 silver pl solder term, 2 fuse clips, 6 resistors, 3
E-13		capacitors, and 1 fuse; wax impregnated phenolic; 4 3/4" lg x 2 1/8"
E-14		wd x 1/8" thk; TRC #833.004; (2 mtg holes #22 drill on 2-13/16"
E-15		centers).
E-16	2Z9418-42	BOARD, terminal: 18 silver pl solder term, 4 resistors, 5 capacitors; wax
E-17		impregnated phenolic; 2-13/16" lg x 1-9/16" wd x 1/8" thk; TRC
E-18		#833.005; (2 mtg holes #22 drill on 2-3/16" centers).
E-19	2Z9412.104	BOARD, terminal: 12 silver pl solder term, 6 resistors; wax impregnated
E-20		phenolic; 4-1/16" lg x 9/16" wd x 1/8" thk; TRC #833.006; (2 mtg
E-21		holes #22 drill on 2 3/4" centers).
E-22	2Z9418.43	BOARD, terminal: 18 silver pl solder term, 9 resistors; wax impregnated
E-23		phenolic; 3 3/8" lg x 1-13/16" wd x 1/8" thk; TRC #833.007; (2 mtg
E-24		holes #22 drill on 2 5/8" centers).

45. MAINTENANCE PARTS LIST FOR SIGNAL GENERATORS TS-155/UP AND TS-155A/UP (cont.)

Ref symbol	Signal Corps Stock No.	Name of part and description
E-9	2Z9414.60	BOARD, terminal: 14 silver pl solder term, 6 resistors, 1 capacitor; wax impregnated phenolic; 2-9/16" lg x 1-13/16" wd x 1/8" thk; TRC #833.008; (2 mtg holes #22 drill on 1 7/8" centers).
E-10	2Z9418.44	BOARD, terminal: 18 silver pl solder term, 9 resistors; wax impregnated phenolic; 9 1/4" lg x 1 1/2" wd x 1/8" thk; TRC #833.009; (6 mtg holes #22 drill, 4 outside mtg holes on 7 5/8" horiz centers and 5/8" vert centers).
E-11	2Z3719-28	DIAL, vernier: brass, nickel pl; bakelite knob; 3" diam calibrated dial; Natl Co dwg #SA-2322; (similar to Natl type "N" assem; dial calibrated 100 CCW on dial in 270°; 4 mtg holes 90° apart on 2.312" diam pitch circle; bushing for 1/4" shaft).
E-12	2Z3719-29	DIAL, vernier: brass, nickel pl; bakelite knob; 3" diam calibrated dial; Natl Co dwg #SA-2322; (similar to Natl type "N" assem; dial calibrated 200 CW on dial in 216°; 4 mtg holes 90° apart on 2.312" diam pitch circle; bushing for 1/4" shaft).
E-13 E-14 E-15	2Z5822-8	KNOB, octagonal: black bakelite; for 1-4" diam shaft; two #8-32 Allen head setscrews located 90° apart; white vinylite pointer 7/8" lg measured from center; 1 1/8" diam; Kurz-Kasch #S-308-64; (brass insert).
E-16		KNOB, octagonal: black bakelite; for 1-4" diam shaft; two #8-32 Allen head setscrews located 90° apart; arrow marking; 1 1/8" diam x 5/8" h; Kurz-Kasch #S-308-64; (brass insert, hole 11/32" d).
E-17		KNOB, octagonal: black bakelite; hole for 13/16" diam shaft; two #6-32 Allen head setscrews located 135° apart; arrow engraved 1/2" lg; 1 1/8" diam x 7/32" d; TRC #431.131; (used with E-18).
E-18	2Z5822-6.1	KNOB, octagonal: black bakelite; hole for 1-4" diam shaft; two #6-32 Allen head setscrews located 90° apart; 1 5/8" diam x 11/32" d; TRC #431.130; (reference line engraved on one protrusion; used with E-17).
E-19	2Z5822-129	KNOB, bar: black bakelite; hole for 1-4" diam shaft; 1-3/16" lg x 7/16" wd x 5/8" d; Natl Co type # HRP.
E-20	2Z5753.27	ANTENNA ASSEMBLY, dipole: one piece; 4 3/4" lg x 1 1/8" h x 2 1/8" wd over-all; SC #AS-23/AP, Sig C dwgs SC-D-#12021, #12022, and #12023; (2 mtg holes, 3/8" on centers, type "N" jack in base).
E-21	2Z5786.46	ADAPTER, connector: type "N" female one end ; SKL female other end; Sig C dwgs #SC-D-11908, #SC-D-11909.

45. MAINTENANCE PARTS LIST FOR SIGNAL GENERATORS TS-155/UP AND TS-155A/UP (cont.)

Ref symbol	Signal Corps Stock No.	Name of part and description
F-1	3Z2603-2	FUSE, cartridge: 3 amp, 250v; one-time; glass body; metal mtg ends 1/4" lg x 1/4" diam; over-all dimen 1 1/4" lg x 1/4" diam; Littelfuse #3AG-1043.
F-2	3Z2572-2	FUSE, cartridge: 1/32 amp, 250v; one-time; glass body; metal mtg ends 1/4" lg x 1/4" diam; over-all dimen 1 1/4" lg x 1/4" diam; Littelfuse #3AG-1261.
F-3	3Z3275-9	FUSE HOLDER: bakelite body; detachable cap 3/8" h x 3/8" diam; over-all dimen 1 3/4" lg x 7/16" diam; (2 solder term on bottom; mts 9/16" hole on 1/2" dia thd).
H-1 H-2 H-3 H-5 H-4	2Z5042-4	CLAMP, tube: type #302 stainless steel; 1 1/4" diam x 3/4" h; Birtcher #926-B; (1 mtg bracket; equipped w/holding spurs).
H-6 H-7	2Z2642.28	CLAMP, tube: type #302 stainless steel; 1 3/8" diam x 17/32" h; Birtcher #926-B-2 (1 mtg bracket; equipped w/holding spurs).
H-11 H-12 H-13 H-14 H-15 H-16 H-17 H-18	2Z2636-28	CLAMP, tube: type #302 stainless steel; 1-5/32" diam x 3/4" h; Birtcher #926-A; (1 mtg bracket; equipped w/holding spurs).
H-8	2Z2636-26	CLAMP, tube: type #302 stainless steel; 1 3/8" diam x 3/4" h; Birtcher #926-C; (1 mtg bracket; equipped w/holding spurs).
H-11 H-12 H-13 H-14 H-15	3F4325-155/3	SCREW, captive thumb: cylindrical head, 7/16" diam, 13/32" thk; steel, nickel pl; #8-32 thd, 5/32" lg; 29/32" over-all lg; TRC dwg #A-1542; (coarse straight knurl; un-threaded portion 0.098" diam).
H-16 H-17 H-18	2C5130-36/58	LOCKING NUT, shaft: brass; nickel pl; base 1/2" hex w/ 3/8" diam hole x 32 thd per inch; nut 7/16" hex x 1/4" d; Millen # 10061; (locks pot shaft; spl thd to tighten base as nut is screwed down).
H-19	3F4325-155/1	NUT, sleeve: aluminum; 17/64" diam x 9/32" lg; #6-32 thd per inch, 3/16" d; small end 7/32" diam x 3/32" lg; medium straight knurl; 5/32" diam hole x 3/32" d; TRC # 523.510.
I-1	2Z5883-205	LIGHT, indicator. (mtg assem); bras body and cap; ebinol finish; miniature bayonet single cont socket; 2-5/16" lg x 7/8" diam; Dialco MDV89; (mts in 11/16" hole).
J-1 J-2	2Z8671.20	CONNECTOR, female contact: UHF coax; straight; 1-1/16" lg x 5/8" diam; Amphenol; Navy #49194; (mica filled bakelite insulation; 24 thd per inch; lg of thd 3/8"; four mtg holes in metal plate 1" sq).

45. MAINTENANCE PARTS LIST FOR SIGNAL GENERATORS TS-155/UP AND TS-155A/UP (cont.)

Ref symbol	Signal Corps Stock No.	Name of part and description
L-1	3C323-34Z	COIL, radio, r-f: choke; integral type; unshielded; 100 uh, 5 ma, d-c resistance approx. 2.7 ohms; 1-9/16" lg x 3/4" diam; Std Coil Prod dg #A-963B; (mts on 6/32" screw; single universal wdg; Phenolic Form, varnish impregnated).
L-2	3C323-34Z1	COIL, radio, r-f: choke; integral type; unshielded; 10 uh, 5 ma, d-c resistance approx. 0.9 ohms; 1-9/16" lg x 7/16" diam; Std Coil Prod dwg #A-963B; (mts on 6/32" screw; single universal wdg; Phenolic Form, varnish impregnated)
L-3	3C328-35	COIL, radio a-f: choke; filter; single winding; 10 hy, 110 ma, d-c resistance 260 ohms; 2 3/4" lg x 2 1/2" wd x 3 1/2" h over-all; Raytheon UX7944 (metal case; four #10-24 mtg studs 1 7/8," mtg/c x 2" mtg/c).
M-1	3F872-2	METER, D.C., microammeter; 0-200 ua; 68 ohms; round, bakelite flush mtg case; 3 1/2" diam flange x 2 3/4" diam body x 1 1/8" d; Marion Electrical Instrument Co; TRC #502 111; (3 mtg holes 9/64" diam on flange spaced 120° apart on circle of 1 5/8" rad; two stud term 1/4"-28 thd x 3/4" lg, 1 3/8" apart).
P-1 P-2	2Z7274-64	RESISTOR, variable: tandem pot; carbon; P-1 1 mg; 2w; P-2, 100,000 ohms; 2w; 3 term in ea pot; body 1 1/8" diam x 7/8," d; CTS #X2024; (linear taper; inclosed body; bushing 3/8" diam x 32 thd per inch x 1/2" lg; concentric shaft; outer shaft protrudes 3/4" from face; inner shaft protrudes 15/16" from face).
P-3	2Z7272.15	RESISTOR, variable: carbon; 500,000 ohms; 2w; 3 term; body 1/16" diam x 9/16" d; AB #U-5041, AB #SD-4040-L; (linear taper; inclosed body; bushing 3/8" diam x 32 thd per inch x 1/2" lg; shaft extends 1/8" from end of bushing, 1/4" diam; shaft end is slotted for screwdriver; locking device).
P-4 P-7	2Z7270.120	RESISTOR, variable: carbon; 50,000 ohms; 2w; 3 term; body 1-1/16" diam x 9/16" d; AB #P-3048, AB #U-5031; (linear taper; inclosed body; bushing 3/" diam x 32 thd per inch x ha" lg; shaft 1/4" diam extends J/4" from bushing).
P-5	2Z7272-208	RESISTOR, variable: carbon; 500,000 ohms; 2w; 3 term; body 1-1/16" diam x 9/16" d; AB #P-3048, AB #B-5041; ("B"-taper counterclockwise logarithmic; inclosed body; bushing 3/8" diam x 32 thd per inch x 3h" lg; shaft 1/4" diam extends 3/8" from bushing).

45. MAINTENANCE PARTS LIST FOR SIGNAL GENERATORS TS-155/UP AND TS-155A/UP (cont.)

Ref symbol	Signal Corps Stock No.	Name of part and description
P-6	2Z7277.58	RESISTOR, variable: WW; 100 ohms; 2w; 3 term; body 1 1/4" diam x 9/16" d; CTS #252; (linear taper; inclosed body; bushing 3/8" diam x 32 thd per inch x 3/8" lg; shaft 1/4" diam screwdriver slot; shaft extends 3/8" from bushing).
P-8	2Z7267.17	RESISTOR, variable: WW; 500 ohms; 2w; 3 term; body 1 1/4" diam x 9/16" d; CTS #252; (linear taper; inclosed body; bushing 3/8" diam x 32 thd per inch x 3/8" lg; shaft 1/4" diam screwdriver slot; shaft extends 3/8" from bushing).
P-9	2Z727-94	RESISTOR, variable: WW; 1,000 ohms; 2w; 3 term; body 1 1/4" diam x 9/16" d; CTS #252; (linear taper; inclosed body; bushing 3/8" diam x 32 thd per inch x 3/8" lg; shaft 1/4" diam x 3/8" lg).
P-10	2Z7280-142	RESISTOR, variable: WW; 5,000 ohms; 4w; 3 term; body 1 1/4" diam x 9/16" d; CTS #25; (linear taper; inclosed body; bushing 3/8" diam x 32 thd per inch x 3/8" lg; shaft 1/4" diam x 3/8" lg).
R-1 R-30	3Z6804A7-1	RESISTOR, fixed: composition; 4.7 meg + 10%; 1/2w; 3/8" lg x 3/64" diam; AB #EB-4751; AWS type #RC20BF-475K; (insulated; 2 axial wire leads 1 1/2" lg).
R-2	3RCBF473K	RESISTOR, fixed: composition; 47,000 ohms ± 10%; 1/2w; 3/8" lg x 9/64" diam; AB #EB-4731; AWS type #RC20-3RF473K; (insulated; 2 axial wire leads 1 1/2" lg).
R-3 R-6	3RC20BF103K	RESISTOR, fixed: composition; 10,000 ohms ± 10%; 1/2w; 3/8" lg x 9/64" diam; AB #EB-1031; AWS type #RC20-BF103K; (insulated; 2 axial wire leads 1 1/2" lg).
R-4	3RC30BF223K	RESISTOR, fixed: composition; 22,000 ohms ± 10%; 1w; 9/16" lg x 7/32" diam; AB #GB-2231; AWS type #RC30-BF223K; (insulated; 2 axial wire leads 1 1/2" lg).
R-5	3RC20BF821J	RESISTOR, fixed: composition; 820 ohms ± 5%; 1/2w; 3/8" lg x 9/64" diam; AB #EB-8215; AWS type #RC20BF-821J; (insulated; 2 axial wire leads 1 1/2" lg).
R-7	3ZK6633-20	RESISTOR, fixed: composition; 27,000 ohms ± 10%; 1/2w; 3/8" lg x 9/64" diam; AB #EB-2731; AWS type #RC20-BF273K; (insulated; 2 axial wire leads 1 1/2" lg).
R-8	3RC20BF332K	RESISTOR, fixed: composition; 3,300 ohms ± 10%; 1/2w; 3/8" lg x 9/64" diam; AB #EB-3321; AWS #RC20BF-332K; insulated; 2 axial wire leads 1 1/2" lg).
R-9 R-13 R-29	3RC20BF105K	RESISTOR, fixed: composition; 1 meg ± 10%; 1/2w; 3/8" lg x 9/64" diam; AB #EB-1051; AWS #RC20BF105K; (insulated; 2 axial wire leads 1 1/2" lg).

45. MAINTENANCE PARTS LIST FOR SIGNAL GENERATORS TS-155/UP AND TS-155A/UP (cont.)

Ref symbol	Signal Corps Stock No.	Name of part and description
R-10a R-10b R-10c	3Z6390-1	RESISTOR, fixed: composition; 3,900 ohms \pm 10%; 2w; 1 3/8" lg x 3/8" diam; Speer #S-12-392K; AWS type #RC 40-BF392K; (insulated; 2 axial wire leads 1 1/2" lg).
R-11	3RC30BP182K	RESISTOR, fixed: composition; 1,800 ohms \pm 10%; 1w; 9/16" lg x 7/32" diam; AB #GB-1821; AWS type #RC-30BF182K; (insulated; 2 axial wire leads 1 1/2" lg).
R-12	3RC20BF272K	RESISTOR, fixed: composition; 2,700 ohm: \pm 10%; 1/2w; 3/8" lg x 9/64" diam; AB #EB-2721; AWS type #RC20-BF272K; (insulated; 2 axial wire leads 1 1/2" lg).
R-14	3RC40AE222K	RESISTOR, fixed: composition; 2,200 ohms \pm 10%; 2w; 1 3/8" lg x 3/8" diam; Speer #S-12-222K; AWS type #RC-40BF222K; (insulated; 2 axial wire leads 1 1/2" lg).
R-15	3RC20BF331K	RESISTOR, fixed: composition; 330 ohms \pm 10%; 1/2w; 3/8" lg x 9/64" diam; AB #EB-3311; AWS type #RC20BF-331K; (insulated; 2 axial wire leads 1 1/2" lg).
R-16	3RC20BE390K	RESISTOR, fixed: composition; 39 ohms \pm 10%; 1/2w; 3/8" lg x 9/64" diam; AB # EB-3901; AWS type RC20BF390K; (insulated; 2 axial wire leads 1 1/2" lg).
R-17	3RC20BFIOIK	RESISTOR, fixed: composition; 100 ohms \pm 10%; 1/2w; 3/8" lg x 9/64" diam; AB #EB-1011; AWS type #RC20BF-101K; (insulated; 2 axial wire leads 1 1/2" lg).
R-18	3Z671546	RESISTOR, fixed: composition; 150,000 ohms \pm 10%; 2w; 1 3/8" lg x 3/8," diam; Speer #S-12-154K; AWS type #RC-40BF154K; (insulated; 2 axial wire leads, 1 1/2 " lg).
R-19	3RC20BF822K	RESISTOR, fixed: composition; 8,200 ohms \pm 10%; 1/2w; 3/8" lg x 9/64" diam; AB #EB-8221; AWS type #RC20BF-822K; (insulated; 2 axial wire leads, 1 1/2" lg).
R-20	3RC30BF.332K	RESISTOR, fixed: composition; 3,300 ohms \pm 10%; 1w; 9/16" lg x 7/32" diam; AB #GB3321 AWS type #RC-30BF332K; (insulated; 2 axial wire leads 1 1/2" lg).
R-21	3RC20BE363J	RESISTOR, fixed: composition; 36,000 ohms \pm 5%; 1/2w; 3/8" lg x 9/64" diam; AB #EB-3635; AWS type #RC20-BF363J; (insulated; 2 axial wire leads 1 1/2" lg).
R-22	3RC20BF102K	RESISTOR, fixed: composition; 1,000 ohms \pm 10%; 1/2w; 3/8" lg x 9/64" diam; AB #EB-1021; AWS type #RC20-BF102K; (insulated; 2 axial wire leads 1 1/2" lg).
R-23	3Z6470-8	RESISTOR, fixed: composition; 4,700 ohms \pm 10% 1/2w; 3/8" lg x 9/64" diam; AB #EB4721; AWS type #RC20-BF472K; (insulated; 2 axial wire leads 1 1/2" lg).
R-24	3RC20BF153K	RESISTOR, fixed: composition; 15,000 ohms \pm 10%; 1/2w; 3/8" lg x 9/64" diam; AB #EB-1531; AWS type #RC20-BF153K; (insulated; 2 axial wire leads 1 1/2" lg).

45. MAINTENANCE PARTS LIST FOR SIGNAL GENERATORS TS-155/UP AND TS-155A/UP (cont.)

Ref symbol	Signal Corps Stock No.	Name of part and description
R-25	3RC40AE393K	RESISTOR, fixed: composition; 39,000 ohms $\pm 10\%$; 2w; 1 3/8" lg x 3/8" diam; Speer S-12-393-K; AWS type #RC40-BF393K; (insulated; 2 axial wire leads 1 1/2" lg).
R-26	3RC30BF153K	RESISTOR, fixed: composition; 15,000 ohms $\pm 10\%$; 1w; 9/16" lg x 7/32" diam; AB #GB-1531; AWS type #RC-30BF153K; (insulated; 2 axial wire leads 1 1/2" lg).
R-27	3Z6390-19	RESISTOR, fixed: WW; 3,900 ohms $\pm 5\%$; 10w; 2 3/8" lg x 15/32" body diam; Sprague # 10F; vitreous enamel insulation; ceramic core; mtg ends diam 9/16"; mts in fuse holder.
R-28a R-28b R-28c	3Z6100-137	RESISTOR, fixed: composition; 1,000 ohms $\pm 10\%$; 2w; 1 3/8" lg x 3/8" diam; Speer #S-12-102K; AWS type #RC-40BF102K; (insulated; 2 axial wire leads 1 1/2" lg).
R-31	3RC20BF104K	RESISTOR, fixed: composition; 100,000 ohms $\pm 10\%$; 1/2w; 3/8" lg x 9/64" diam; AB #EB-1041; AWS type #RC20-BF104K; (insulated; 2 axial wire leads 1 1/2" lg).
R-32 R-33 R-34 R-37	3RC20BF241J	RESISTOR, fixed: composition; 240 ohms $\pm 5\%$; 1/2w; 3/8" lg x 9/64" diam; AB #EB-2415; AWS type #RC20BF-241J; (insulated; 2 axial wire leads 1 1/2" lg).
R-35	3Z6926-12.4	RESISTOR, thermal: bead thermistor glass envelope 33-47 ohms with 25 ma; 13/32" lg x 1/8" diam WECO #D163903; (glass insulation; axial wire leads 1 3/4" lg).
R-38	3RC20BE200J	RESISTOR, fixed: composition; 20 ohms $\pm 5\%$; 1/2w; 3/8" lg x 9/64" diam; AB #EB-2005; AWS type #RC20BF-200J; (insulated; 2 axial wire leads 1 1/2" lg).
R-39	3Z6926-12	RESISTOR, thermal: disk thermistor; approx 803 ohms at 75°F; $\pm 5\%$; over-all height 5/16"; WECO #D168392; mtg rectangular metal plate 1 1/4" lg x 7/8" wd; 4 mtg holes 1" apart horizontally and 5/8" apart vertically; flexible wire lead 4" lg.
R-40	2Z6926-11	RESISTOR thermal: disk thermistor; approx 765 ohms at 75°F; $\pm 5\%$; mtg rectangular metal plate 1 1/4" lg x 7/8" wd; over-all height 5/16"; WECO #D-168391; mtg holes 1" apart horizontally, 5/8" apart vertically; flexible wire lead 4" long.
R-41	3RC20BF471J	RESISTOR, fixed: composition; 470 ohms $\pm 5\%$; 1/2w; 3/8" lg x 7/64" diam; AB #EB-4715; AWS type #RC20BF-471J; (insulated; 2 axial wire leads 1 1/2" lg).
R-42	3RC20BF360J	RESISTOR, fixed: composition; 36 ohms $\pm 5\%$; 1/2w; 3/8" lg x 9/64" diam; AB #EB-3605; AWS type #RC20BF360J; (insulated; 2 axial wire leads 1 1/2" lg).

45. MAINTENANCE PARTS LIST FOR SIGNAL GENERATORS TS-155/UP AND TS-155A/UP (cont.)

Ref symbol	Signal Corps Stock No.	Name of part and description
R-43	3ZK6003J1-11	RESISTOR, fixed: composition; 39 ohms $\pm 5\%$; 1/2w; 3/8" lg x 9/64" diam; AB #EB-3905; AWS type #RC20BF-390J; (insulated; 2 axial wire leads 1 1/2" lg).
R-44a R-44b R-44c R-45	3Z6120-11 3Z6568-28	RESISTOR, fixed: composition; 1,200 ohms $\pm 10\%$ 2w; 1 3/8" lg x 3/8" diam; Speer #S-12-122K; AWS Type #RC40-BF122K; (insulated; 2 axial wire leads 1 1/2" lg). RESISTOR, fixed: WW; 6,800 ohms $\pm 5\%$; 20w; 2 3/8" lg x 15/32" body diam; Sprague #20F; vitreous enamel insulation; ceramic core; mtg ends diam 9/16"; mets In fuse holder.
R46	3RC20BF223K	RESISTOR, fixed: composition; 22,000 ohms $\pm 10\%$; 1/2w; 3/8" lg x 9/64" diam; AB #EB-2231; AWS type #RC20-BF223K; (insulated; 2 axial wire leads 1 1/2" lg).
R-48	3RC20BF825K	RESISTOR, fixed: composition; 8.2 meg $\pm 10\%$; 1/2w; 3/8" lg x 9/64" diam; AB #EB-8251; AWS type #RC20BF-825K; (insulated; 2 axial wire leads 1 1/2" lg).
S-1 S-4 S-2	3Z9849.10-4	SWITCH, toggle: DPDT; black bakelite; 1/8" lg x 1/4" wd x 1" h; C-H #8373; (250v, 3 amp; bushing 1/2" lg x 1/2" diam). SWITCH, rotary: 3 poles ea sect; 3 positions; 2 sect; ceramic body; 2" diam x 2 5/8" lg; TRC #800.120; (shaft 1/4" diam x 3/8" lg; bushing 3/5" diam x 3/s" lg; solder lug term).
S-3	3Z9849.28	SWITCH, toggle: SPST; black bakelite; 1 3/8" lg x 1/2" wd x 1" h; C-H #8381; (250v, 3 amp; bushing 1/2" lg x 1/2" diam).
T-1	2Z9638-41	TRANSFORMER, a-f: (blocking osc); 50-2,500 cps; painted steel case; 2 3/4" h x 1 3/8" diam over-all; Wemco type #145-EWP; (6 solder term at bottom; flange mtg, 3 mtg holes 0.149 diam 120° apart on 1 7/8" pitch circle; flange 2-5/32" diam; 3 windings).
T-2	3Z9619-93	TRANSFORMER, power: plate and filament; fully enclosed steel case; 4" lg x 3 1/2" wd x 5 3/4" h; Raytheon #UX-7943, or Amertran equivalent; Templetone Radio Mfg Corp dwg #C-1265; (pri-50-800 c, 115/230v; sec #1-700v at 110 ma CT; sec #2-5.0v at 3 amp; sec #3-6.3v at 4 amp; 4 mtg lugs 3/16" diam x 24 thd per in. x 1/2" long; 3" mtg/c x 2 7/8" mtg/c; 10 insulated term on bottom).
V-1 V-2 V-3 V-5	2J6SN7GT	TUBE, electron: JAN-6SN7GT; twin triode.
V-4	2J6AG7	TUBE, electron: JAN-6AG7; power amplr pent.

45. MAINTENANCE PARTS LIST FOR SIGNAL GENERATORS TS-155/UP AND TS-155A/UP (cont.)

Ref symbol	Signal Corps Stock No.	Name of part and description
V-6 V-7 V-8 V-9 W-1	2JOD3/VR150 2JOC3/VR105 2JSU4G 2J2C40 2J446B	TUBE, regulator: JAN-OD3, VR-150. TUBE, regulator: JAN-OC3/VR-105. RECTIFIER, electron tube: JAN-5U4G. TUBE, ELECTRON: JAN-2C40 TUBE, electron: #446B (possible alternate).
W-2	1F425-59.708	CABLE ASSEMBLY, r-f: coax; Army-Navy r-f cable #RG--38 U; flexible; characteristic impedance 50 ohms; 9" lg between plugs; inner cond # 17 AWG tinned copper; synthetic rubber compound dielectric; Templetone Radio Mfg. Corp.) 152.001; (2 copper shielding braids; waxed cotton braid outer covering; AN #UG-16'U jack on one end; AN ;UG-15. U plug on one end).
W-3	1F430-70	CABLE ASSEMBLY, r-f: coax; AN r-f cable #RG-5/U; flexible; characteristic impedance 51 ohms; 15 ft between plugs; inner cond #16 AWG copper; stabilized polyethylene dielectric; A-N Cable Assembly CG-70/ MPM; (2 shielding braid; vinyl outer covering; 2 plugs UG-18/U)
W-4	1F430-71	CABLE ASSEMBLY, r-f: coax: AN r-f cable #RG-11/U; flexible; characteristic impedance 75 ohms; 6 ft between plugs; inner cond 7/26 AWG copper; stabilized polyethylene dielectric; A-N Cable Assembly CG-7 1 MPM; (1 shielding braid; vinyl outer covering; 2 plugs PL-259).
X-1 to X-8	2Z8678.202	SOCKET, tube: std octal; ceramic; 1 1/8" diam x 7/8" h over-all; UCINITE 115001-1A; (mts by means of metal saddle on 1 1/2" mtg/c).
+1	3F4325-155/2	CAVITY OSCILLATOR, tunable: Sq band; Presto Recording Corp. dwg #58-5366-C.
+2		POINTER, round head; brass, nickel pl; #6-32 thd screw 1/2" lg; 5/16" diam head; Bud Rad #IN-1736.
+3		SHAFT ASSEMBLY: 1/4" shaft and coupling for 1/4" and 1/4," shafts; over-all 6-5/8" TRC #313.002 diam of coupling 1".
	Order No. 650-SCRL-42, 2500 copies printed 14 February, 1945.	

*U.S. GOVERNMENT PRINTING OFFICE: 1980-323-439/317

RECOMMENDED CHANGES TO EQUIPMENT TECHNICAL PUBLICATIONS



THEN... JOT DOWN THE DOPE ABOUT IT ON THIS FORM, CAREFULLY TEAR IT OUT, FOLD IT AND DROP IT IN THE MAIL!

SOMETHING WRONG WITH THIS PUBLICATION?

FROM: (PRINT YOUR UNIT'S COMPLETE ADDRESS)

DATE SENT

PUBLICATION NUMBER

PUBLICATION DATE

PUBLICATION TITLE

BE EXACT... PIN-POINT WHERE IT IS

PAGE NO.	PARA-GRAPH	FIGURE NO.	TABLE NO.
----------	------------	------------	-----------

IN THIS SPACE TELL WHAT IS WRONG AND WHAT SHOULD BE DONE ABOUT IT:

TEAR ALONG PERFORATED LINE

PRINTED NAME, GRADE OR TITLE, AND TELEPHONE NUMBER

SIGN HERE:

DA FORM 2028-2
1 JUL 79

PREVIOUS EDITIONS ARE OBSOLETE.

P.S.—IF YOUR OUTFIT WANTS TO KNOW ABOUT YOUR RECOMMENDATION MAKE A CARBON COPY OF THIS AND GIVE IT TO YOUR HEADQUARTERS.

PIN: 029220-002